

MAC Ultra Performance

User Guide



Martin[®]
by HARMAN

User Documentation update information

All important changes in the MAC Ultra Performance User Guide are listed below.

Revision C

Covers MAC Ultra Performance firmware version 1.5.0. Added pre-programmed FX (controllable via DMX). Added Extended DMX Mode. Added info on cold start behavior. Keylight calibration available in control panel and via RDM. Added note on CMY flag speed limitations when using P3 control. Some changes in control menu options.

Revision B

Covers MAC Ultra Performance firmware version 1.2.0. Added PWM frequency adjustment, details of cold start vs. steady state output level. Minor corrections including corrections to followspot functionality.

Revision A

First version released. Covers MAC Ultra Performance firmware version 1.0.0

©2020-2021 HARMAN PROFESSIONAL DENMARK ApS. All rights reserved. Features, specifications and appearance are subject to change without notice. HARMAN PROFESSIONAL DENMARK ApS and all affiliated companies disclaim liability for any injury, damage, direct or indirect loss, consequential or economic loss or any other loss occasioned by the use of, inability to use or reliance on the information contained in this document. Martin is a registered trademark of HARMAN PROFESSIONAL DENMARK ApS registered in the United States and/or other countries.

HARMAN PROFESSIONAL DENMARK ApS, Olof Palmes Allé 44, 8200 Aarhus N, Denmark
HARMAN PROFESSIONAL SOLUTIONS U.S., 8500 Balboa Blvd., Northridge CA 91329, USA

www.martin.com

Contents

Introduction	4
Operating the fixture	5
Effects	6
Shutter and strobe effects	6
Dimming	6
Color mixing	6
Color temperature control	6
Color wheel	6
Rotating gobos	7
Animation wheel	9
Frost	9
Optional heavy frost filters	9
Rotating prism	9
Iris	9
Framing	9
Zoom and focus	10
Pan and tilt	10
LED PWM frequency control	11
Pre-programmed FX	11
Control panel	12
Control options	15
DMX	15
P3 video	16
RDM	16
Fixture setup	19
Fixture ID	19
Personality	19
Managing fixture settings	22
Fixture information readouts	22
Temperatures	23
DMX signal monitoring	23
Test sequences	23
Manual control	23
Service	24
Adjusting settings via DMX	25
Resetting	25
Illuminating the display	25
Control menu setting overrides	25
Adjusting calibration offsets via DMX	25
Adjusting keylight calibration via DMX	26
DMX protocol	27
Basic Mode	27
Extended Mode	33
FX: pre-programmed effects	39
Control panel menus	44
Service and display messages	49
Warning messages	49
Error messages	50

Introduction



Warning! Before installing, operating or servicing the MAC Ultra Performance lighting fixture, read the latest version of the fixture's Safety and Installation Manual, paying particular attention to the Safety Precautions section. The Safety and Installation Manual is supplied with the fixture. The latest version is also available for download from the MAC Ultra Performance area of the Martin® website at www.martin.com.

Thank you for selecting a MAC Ultra Performance moving head lighting fixture from Martin®.

This User Guide is a supplement to the Installation and Safety Manual that is supplied with the fixture. Both these documents are available for download from the MAC Ultra Performance area of the Martin website at www.martin.com. This User Guide contains information that is mainly of interest for lighting designers and operators, whereas the Safety and Installation Manual contains important information for all users, especially installers and technicians.

We recommend that you check the Martin website regularly for updated documentation, because we publish revised versions each time we can improve the quality of the information we provide and each time we release new firmware with changes or new features. Each time we revise this guide we list any important changes on page 2 so that you can keep track of updates.

The MAC Ultra Performance moving-head spotlight offers the following features:

- Bright 1150 W light engine
- Fixture output of 46 500 lumens
- High-contrast optics with flat field and low distortion
- Exceptionally low noise
- Full-range dimming with four dimming curve options
- Electronic shutter effect with variable speed regular and random strobe
- CMY color mixing
- Continuously variable Color Temperature Control from 6000 to 2850 K
- 6-slot color wheel including spectral enhancement filter for added color choice and split color effects
- Two rotating gobo wheels, each with 5 rotating gobos
- Gobo animation wheel that can be inserted horizontally, vertically and diagonally, with continuous bi-directional rotation
- 4-blade rotating framing module with +/- 83° of movement and variable blade angle of 30° through full insertion range
- 4-facet rotating prism
- Iris with continuous adjustment and pulse effects
- Variable frost for smooth wash effects
- Optional heavy frost filter replacement for prism
- Optional heavy frost filter replacement for standard frost filter
- 1:7 fast-action zoom
- Motorized focus with zoom/focus tracking option
- 540° of pan and 268° of tilt with user-settable pan and tilt limits
- Basic and Extended DMX Modes, with additional 16-bit control functions in Extended Mode
- Wide range of pre-programmed dynamic FX
- Followspot functionality with integrated handles
- Standard DMX, Art-Net and sACN control, RDM monitoring and setup
- Integration with Martin P3 system controllers for video mapping of intensity, color or both
- Variable crossfading between DMX and video control
- Martin P3 system controllers feature remote setup, patching and monitoring
- Backlit graphic display
- Disposable lithium battery allowing fixture setup without mains power

Operating the fixture

Before applying power to or operating the MAC Ultra Performance:

- Read the 'Safety Information' section of the fixture's Safety and Installation Manual that is supplied with the fixture and available for download from the Martin website at www.martin.com.
- Check that the installation is safe and secure.
- If the fixture is moved from a cold to a warm environment, remove it from its flightcase or packaging and give it at least two hours to acclimatize before applying power. This will help to avoid damage due to condensation.
- Check that the fixture is in perfect condition. Do not apply power to a fixture that is obviously damaged, or you may create a safety risk and make the damage worse.
- Check that the base is fastened securely so that the torque reaction when the head moves will not cause the base to move.
- Check that the head tilt lock is released.
- Be prepared for the head to move suddenly. Check that there will be no risk of collision with persons or objects.
- Be prepared for the fixture to light up suddenly. Check that no-one is looking at the fixture from close range.

The fixture does not have an On/Off switch. To apply power to the fixture, connect the power input cable to a source of AC power that is within the range 200-240 V (nominal), 50/60 Hz. The fixture's Neutrik powerCON TRUE1 TOP connectors can also be connected live or under load.

Note that whenever power is applied to the fixture, it will reset all effects and functions to their home positions and the fixture head will move. This process takes several seconds.

Cold startup behavior

The fixture behaves as follows when starting up from cold:

- Luminous output at cold startup can be up to approximately 15% higher than the steady state output. Output reaches the specified level when the fixture reaches its steady state temperature after approximately 5 minutes (in Fan Regulated mode).
- Power to effects motors is increased until the internal temperature reaches 20°. For a short period this will result in slightly more noise from CMY and other mechanical effects.
- The FAST mode in EFFECTS SPEED is only available when the fixture has warmed up. EFFECTS SPEED is set to NORMAL during warmup.

Effects

This section gives details of the effects available in the MAC Ultra Performance. See the DMX protocol table on page 27 for a list of channels and commands used to control the effects via DMX.

Where fine control is available, the main control channel sets the first 8 bits (the most significant byte or MSB), and the fine channels set the second 8 bits (the least significant byte or LSB) of the 16-bit control byte. In other words, the fine channel works within the position set by the coarse channel.

Shutter and strobe effects

The fixture's electronic shutter effect provides instant blackout and snap open as well as regular or random strobe and pulse effects with variable speed from approx. 1 Hz to 20 Hz.

Dimming

Smooth 0-100% overall dimming is available with 16-bit control resolution. Four dimming curves are available (see Figure 6 on page 20).

Color mixing

The fixture features dichroic CMY color filters, with 16-bit continuous color mixing available on six DMX channels.

Color temperature control

16-bit color temperature control is available on two dedicated CTO channels. You can adjust the fixture's color temperature smoothly and continuously from 6000 K to 2850 K.

Color wheel

The fixture provides a color wheel that lets you select from six dichroic color filters plus open (see Figure 1).

The color wheel can be scrolled continuously with variable speed and direction.

All color filters are interchangeable.

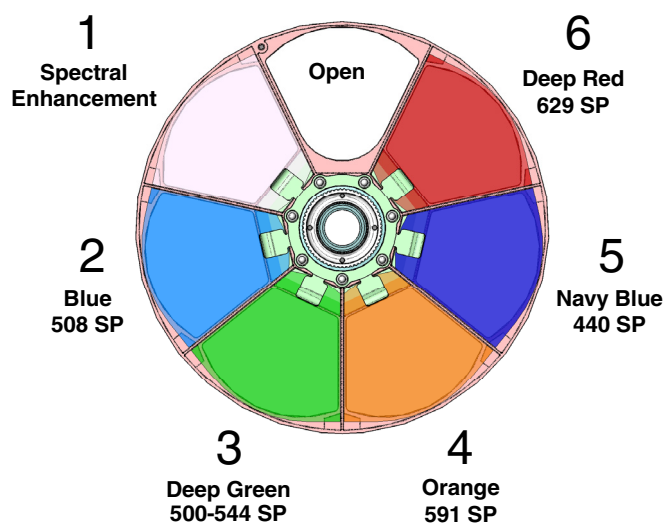

Wheel seen from LED side

Figure 1: Color wheel

Rotating gobos

The gobos on Gobo Wheel 1 and 2 in the MAC Ultra Performance have the same dimensions and specifications and are therefore interchangeable, but the goboholders on the two gobo wheels are different. You cannot move a goboholder from one gobo wheel to the other.

We number gobo wheels in Martin fixtures in the order that the light from the source reaches them. In the MAC Ultra Performance:

- The wheel closer to the LEDs is Gobo Wheel 1, the Aerial Wheel.
- The wheel closer to the front lens is Gobo Wheel 2, the Breakup Wheel.

Aerial Wheel – Gobo Wheel 1

The Aerial Wheel, Gobo Wheel 1, has five rotating gobos that can be used in any situation but are especially suitable for midair effects. Gobos can be selected, indexed (positioned at an angle), rotated continuously and shaken (bounced). Gobo selection and control type (indexing, continuous gobo rotation or gobo shake) are set on channel 13. Depending on what is selected on this channel, the gobo indexed angle or gobo rotation speed are set on channels 14 and 15 with 16-bit control resolution.

The standard gobos are shown in the correct order in Figure 2. All gobos are interchangeable. The MAC Ultra Performance Safety and Installation Guide contains details of gobo replacement procedures.

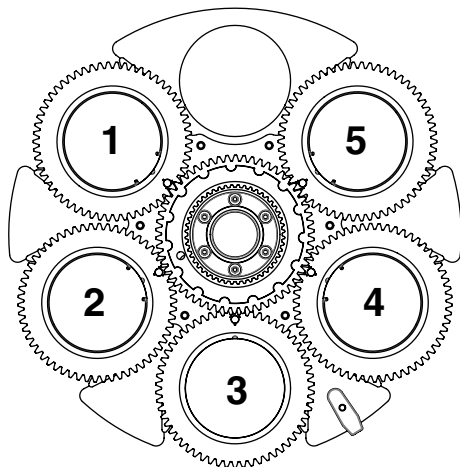
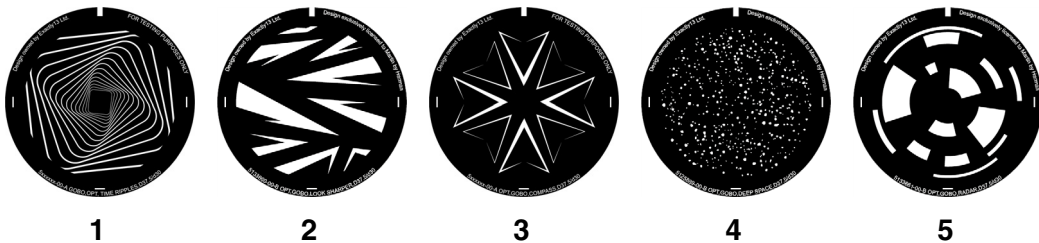

Aerial Wheel seen from LED side

Slot - Gobo	Part number
1. Time Ripples	P/N 5125897-00
2. Look Sharper	P/N 5133660-00
3. Compass	P/N 5125894-00
4. Deep Space	P/N 5125889-00
5. Radar	P/N 5133661-00

Figure 2: Rotating gobos installed on Aerial Wheel as standard

Breakup Wheel – Gobo Wheel 2

The Breakup Wheel, Gobo Wheel 2, has five rotating gobos that can be used in any situation but are especially suitable for breakup effects when used together with the animation wheel. Gobos can be selected, indexed (positioned at an angle), rotated continuously and shaken (bounced). Gobo Wheel 2 selection and control type (indexing, continuous gobo rotation or gobo shake) are set on channel 16. Depending on what is selected on this channel, the gobo indexed angle or gobo rotation speed are set on channels 17 and 18 with 16-bit control resolution.

The standard gobos are shown in the correct order in Figure 3. All gobos are interchangeable except Gobo 3 (Limbo), which is fused glass and is glued into a special goboholder. The MAC Ultra Performance Safety and Installation Guide contains details of gobo replacement procedures.

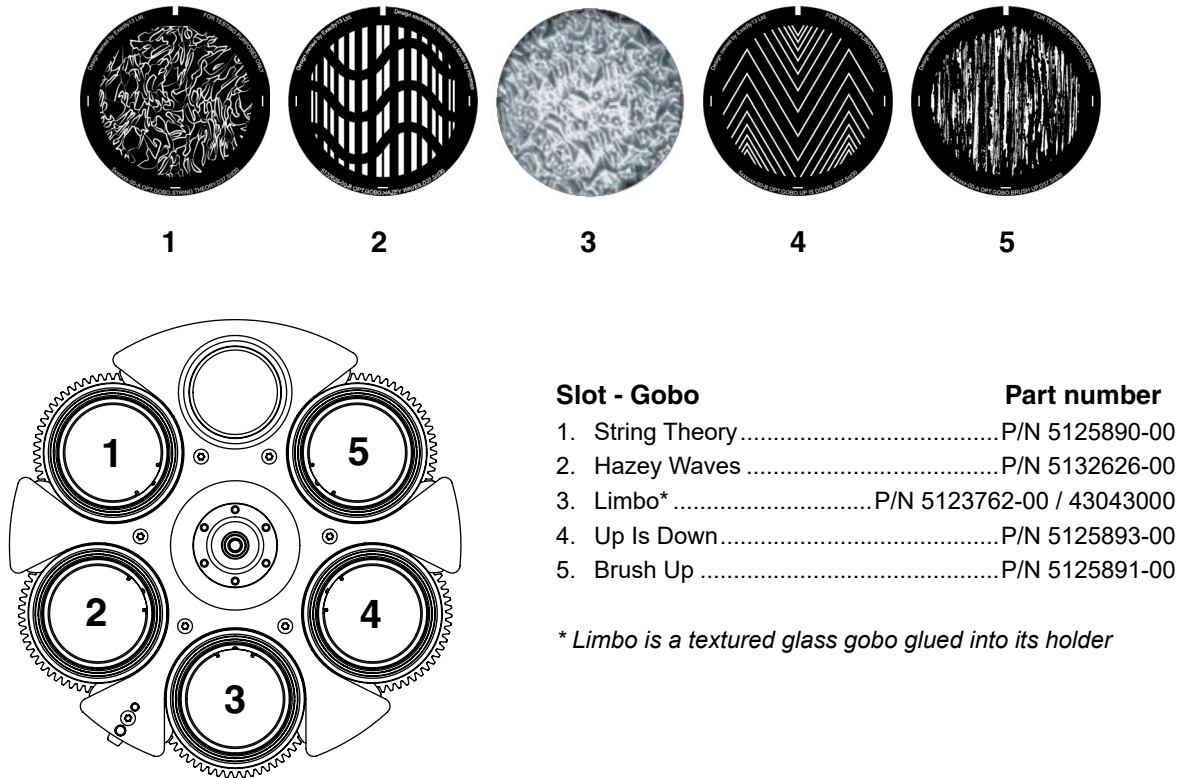

Breakup Wheel seen from LED side

Figure 3: Rotating gobos installed on Breakup Wheel as standard

Animation wheel

The MAC Ultra Performance is supplied with the “Worms That Turn” animation wheel installed. The wheel can be used to add animation effects to gobo projections.

When using gobo animation, adjust the fixture’s focus to obtain the most realistic results.

Frost

The fixture has a frost effect that can be partially or fully inserted into the beam to give a wash-type projection and soften gobo outlines.

Note that using the frost effect at the narrowest zoom angles will affect the zoom lens position. From around 12° cutoff angle, the frost effect does not affect the zoom setting.

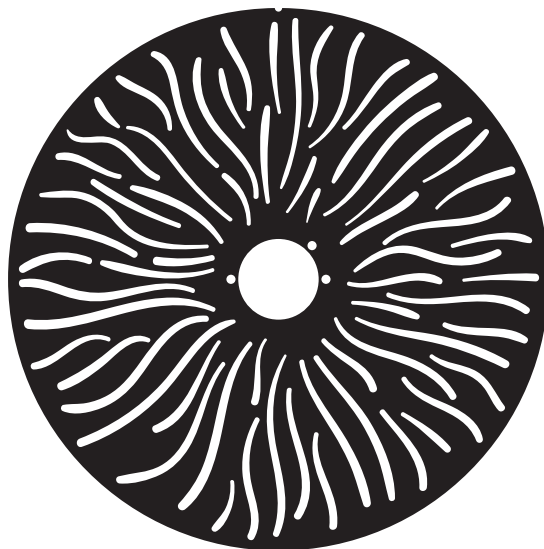

Figure 4: ‘Worms That Turn’ animation wheel

Optional heavy frost filters

An optional heavy frost filter, *P/N MAR-91614060HU, MAC Ultra Heavy Frost - Prism Replacement*, is available as an accessory and can be installed in the fixture in place of the prism. As this frost effect is heavy, it is not primarily intended for use together with gobos. Its main value is that it can soften the edges of the framing blades or give a ‘real’ wash effect. As this filter replaces the prism, it has in/out operation – it is not variable.

Another optional heavy frost filter accessory, *P/N MAR-91614063HU, MAC Ultra Heavy Frost - Frost Replacement* can be installed in place of the standard frost filter. This option lets you keep the prism. As with the standard frost filter, you can vary the extent to which this filter is inserted into the beam.

Installation of either of the two frost filters typically takes less than two minutes. The installation procedures for the filters are covered in the MAC Ultra Performance Safety and Installation Manual supplied with the fixture and available for download from www.martin.com.

Rotating prism

The MAC Ultra Performance has a four-facet circular prism that can be inserted into the beam at indexed angles or rotated with variable direction and speed to give multiple beam effects.

Note that inserting the prism slightly reduces the narrowest zoom angle available.

Iris

The iris can be varied continuously to smoothly reduce the diameter of the beam. Opening and closing pulse effects with variable speed are also available.

The iris can be controlled with 16-bit resolution in Extended DMX Mode.

Framing

The MAC Ultra Performance’s framing module has 4 individually controllable framing blades with fully variable angle of +/-30° through the entire insertion path from 0-100% (full curtain). The whole framing module can rotate through +/-83°.

The framing blades have independent control of angle and amount of insertion for each blade. Adjusting these parameters gives enormous flexibility in forming the beam into shapes of different sizes with three or four sides. It is possible to angle the framing blades *before* inserting them into the beam – a feature unique to this fixture that gives more creative possibilities.

With the fixture installed in a lighting rig with the head below the base and with the head the right way up, the framing blades are numbered counting clockwise from the 12 o'clock position:

- Blade 1 = Top
- Blade 2 = Right
- Blade 3 = Bottom
- Blade 4 = Left

16-bit control of framing blade position and angle and 16-bit control of framing module angle are available in Extended DMX Mode.

Zoom and focus

Adjusting focus lets you vary the sharpness of projected images at different distances. It can be particularly effective when used together with gobos and the animation wheel.

The MAC Ultra Performance's zoom lens varies the focused beam angle from 7.7° to 53°. Wide zoom angles allow sharp focus on projection surfaces close to the fixture. At narrower zoom angles, sharp focus is only possible further from the fixture.

If zoom is set to the narrowest position, it is not possible to focus on all effects at all distances. So when Zoom/Focus tracking is disabled:

- You can find the narrowest zoom angle at which sharp focus is possible by setting focus to DMX value = 0, then starting at the narrowest zoom angle and gradually moving towards wide until you achieve sharp focus.
- At the widest zoom angle, simply set zoom to widest and adjust focus until you achieve sharp focus.

When Zoom/Focus tracking is enabled, we suggest that you set zoom to medium and then change the focus setting until you achieve sharp focus with the desired effect. Changing the zoom angle will now automatically change focus to keep a relatively sharp focus (some fine tuning may be necessary if you want the sharpest focus). Not all effects can be in sharp focus at all zoom settings. At some combinations of effect and distance, zooming to the widest or narrowest angles can cause loss of focus if the effect is no longer within its focusable zoom range at that distance.

Zoom/focus linking

Focus varies with zoom angle, but focus can be linked to zoom so that it automatically adjusts to match changes in zoom angle. Focus on rotating gobos matches zoom closely, while focus on the animation wheel matches zoom best in the center of the zoom range and slightly less precisely at the two extremes of the zoom range.

Linked zoom/focus works within 3 distance ranges: close-, medium- and long-range. The ranges are as follows (figures are approximate):

- Close (5 - 10 meters / 16.5 - 33 ft.)
- Medium (10 - 20 meters / 33 - 66 ft.)
- Long (20 meters - infinity / 66 ft. - ∞)

To link zoom and focus, select a distance range using the Control/Settings DMX channel or **FOCUS TRACKING** in the control panel **PERSONALITY** menu. Then adjust focus to obtain the required degree of sharpness. Linking is now enabled and focus will auto-adjust to match changes in zoom angle.

Pan and tilt

The MAC Ultra Performance offers 540° of pan and 268° of tilt.

16-bit pan and tilt control are available. In each case, the second (LSB) DMX channel adjusts the position set on the first (MSB) channel.

It is possible to set limits for the pan and tilt range (see details on page 19).

LED PWM frequency control

The PWM frequency of the MAC Ultra's LEDs has been chosen carefully to avoid flickering on camera. In some rare situations – for example when using cameras with non-standard settings – it may be necessary to adjust the LED PWM frequency manually.

From firmware version 1.2.0, you can adjust the PWM frequency via DMX by sending value 255 on either the FX1 Selection or the FX2 Selection channel. Once activated, the corresponding FX Speed and Direction channel will control the LED PWM frequency. Note that this change is not stored permanently in the fixture, so you have to keep the FX Selection and FX Speed/Direction channels at the chosen values in order to keep the LED PWM frequency at the corresponding custom value.

You can adjust PWM frequency as follows:

DMX value sent on FX Speed and Direction channel	LED PWM frequency
0 - 127	Adjustment in steps from 2400 to 3000 Hz
128	Default PWM frequency (3000 Hz)
129 - 254	No function
255	High-speed PWM Frequency Mode (24 000 Hz)

Table 1. PWM frequency adjustment values

High-speed PWM Frequency Mode drives the LEDs at 24 000 Hz. This frequency greatly reduces electronic switching noise but it gives slightly faster cut-off at the low end of the dimming range.

The default PWM frequency is 3000 Hz.

Pre-programmed FX

From firmware version 1.5.0 the MAC Ultra Performance offers a range of pre-programmed effect macros that we simply call FX. See a full description under "FX: pre-programmed effects" on page 39

FX give instant access to complex dynamic effects with no need for time-consuming programming at the controller.

Control panel

You can configure individual fixture settings (such as the fixture's DMX address), read out data, execute service operations and view error messages using the fixture's backlit graphic display and control panel.

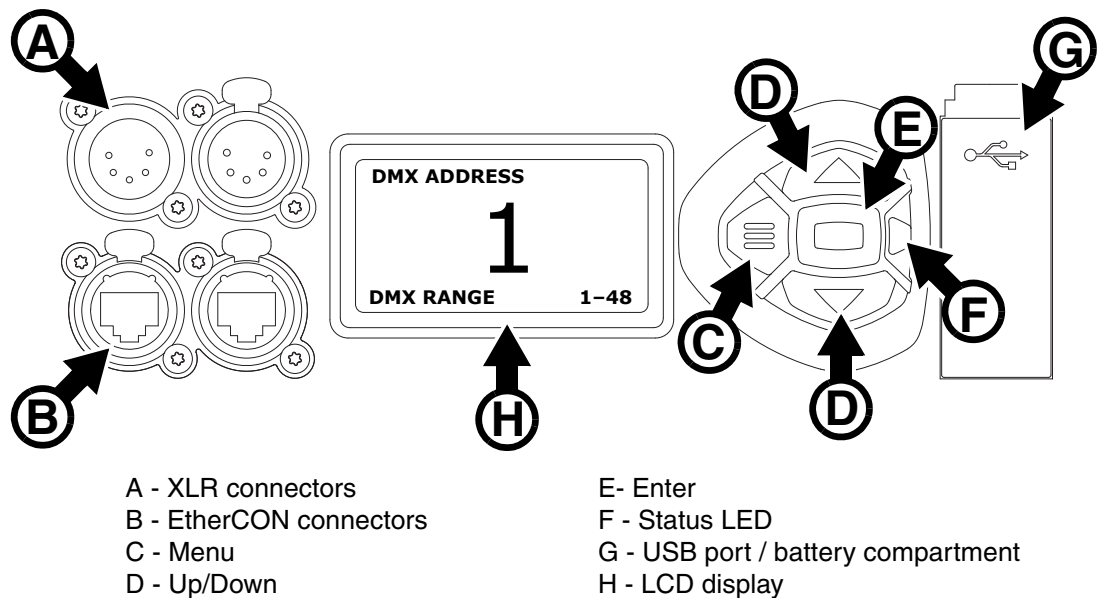

Figure 5: Display and control panel

When the MAC Ultra Performance is powered on, it first boots and resets, then it displays its DMX address (or its fixture ID number, if one has been set) and any status messages (see page 49) in the display **H**.

The display can be set to automatically rotate to match standing or hanging fixture orientation in the **PERSONALITY** → **DISPLAY** menu or the Shortcuts menu (see "Shortcuts" on page 13).

Using the control panel

- Press the MENU button **C** or Enter button **E** to access the menus.
- Use the UP and DOWN buttons **D** to scroll up and down menus.
- Press the ENTER button **E** to enter a menu or make a selection.
- The currently selected item in a menu is indicated by a star ✱.
- Press the MENU button **C** to step backwards through the menus.

Status LED

The LED **F** next to the control buttons indicates fixture status by showing a color and DMX status by flashing or lighting constantly:

- **GREEN**: All parameters normal.
- **AMBER**: Warning (service interval exceeded, for example).
If **ERROR MODE** is set to **Normal**, the warning message will be shown in the display. If **ERROR MODE** is set to **Silent**, the display must be activated by pressing the Enter button **E** to display the warning message.
- **RED**: Error detected.
 - If **ERROR MODE** is set to **NORMAL**, the error message will be shown in the display.
 - If **ERROR MODE** is set to **SILENT**, display the error message by entering the menus and going to **SERVICE** → **ERROR LIST**.

- **FLASHING:** No DMX signal detected.
- **CONSTANT:** Valid DMX signal detected.

The status LED remains active even if the display enters sleep mode.

Battery power

Warning! The fixture's lithium battery is not rechargeable. Do not try to recharge it. If the battery is discharged, obtain a replacement from your Martin supplier.

The MAC Ultra Performance contains a CR123A 3-volt lithium battery in a compartment **G** next to the control panel. The battery gives access to the most important functions in the control panel when the fixture is not connected to AC power. The following functions are available on battery power:

- DMX address
- DMX Mode (Basic or Extended)
- Fixture ID
- Personality settings (pan/tilt, cooling, fan clean mode, dimming curve, DMX reset, parameter shortcuts, all display settings, error mode)
- Default settings
- Information (Power On Hours and Power Cycles counters, Software version)
- Error list

To activate the display when the fixture is not connected to power, press the MENU button **C**. Press again to enter the menus. The display extinguishes after 10 seconds with no user input and the control panel is de-activated after 1 minute with no user input. Press the MENU button **C** again to re-activate.

Shortcuts

If you hold the MENU button **C** pressed in for 2 - 3 seconds, a shortcut menu with the most important commands appears. Select a command with the UP and DOWN buttons **D** and press the ENTER button **E** to activate, or press the MENU button **C** again to cancel.

- **RESET ALL** resets the whole fixture
- **ROTATE DISPLAY** rotates the MAC Ultra Performance display 180°
- **FOLLOWSPOT TOGGLE** puts the fixture into / takes the fixture out of Followspot Mode (see 'FOLLOWPOT MODE' on page 19)
- **TOGGLE HOLD POSITION** uses the pan and tilt motors to hold the head in its current position – a feature that is designed to be used in Followspot Mode when the operator wants to hold the head in a static position for a period.

Settings stored permanently

The following settings are stored permanently in the fixture memory and are not affected by powering the MAC Ultra Performance off and on or by updating the fixture software:

- DMX address
- DMX Mode
- Fixture ID
- Personality settings (pan/tilt, cooling, dimming curve, DMX reset, effect shortcuts, display settings, error mode, etc.)
- Resettable and non-resettable counters
- Service settings (adjustment, calibration)

These settings can be returned to factory defaults using the control menus or via DMX.

Activating service mode

Holding the MENU and ENTER buttons **C** and **E** both pressed in while powering the fixture on puts the fixture into service mode, in which pan and tilt are disabled and a **SERV** warning appears in the display. Service mode removes the risk of unexpected head movement during service adjustments.

To take the fixture out of SERVICE mode, power the fixture off, then reapply power and allow the fixture to start normally.

Control options

You can control the MAC Ultra Performance using DMX and/or Martin P3 protocol. The fixture auto-senses the type of data that it is receiving and will respond correctly with no need for manual protocol selection.

The following options are available:

- DMX control over standard DMX cable connected to the fixture's 5-pin XLR connectors.
- DMX control using Art-Net over Ethernet cable connected to the fixture's etherCON connectors.
- DMX control using streaming ACN over Ethernet cable connected to the fixture's etherCON connectors.
- DMX control over DMX cable and P3 video data over Ethernet cable.
- P3 video data with embedded DMX commands over Ethernet cable. If you connect DMX / Art-Net / sACN to the P3 system controller, the controller can merge the DMX commands into the P3 signal and send them to the fixture over Ethernet.

The P3 Mix DMX channel lets you choose how the fixture should behave if it receives both DMX data and P3 video data. You can use the P3 video pixel data to control the intensity and/or the color of the fixture's output with real-time control.

Fail-safe connection

The MAC Ultra Performance has a fail-safe network connection. If the fixture loses power or if you shut it down, it will continue to relay an Ethernet signal, and the Art-Net / sACN / P3 signal to the other networked fixtures in the daisy chain will not be interrupted.

Data rate

Any Ethernet switch used to relay Art-Net, streaming ACN or P3 data to the MAC Ultra Performance must be capable of running at 10/100 Mbps speed, as the fixture does not support Gigabit Ethernet data rates.

DMX

The MAC Ultra Performance accepts a DMX-512A data signal.

DMX setup

The DMX address, also known as the start channel, is the first channel used to receive instructions from the controller. For independent control, each fixture must be assigned its own control channels. If you give two fixtures of the same type the same address, they will behave identically. Address sharing can be useful for diagnostic purposes and symmetrical control, particularly when combined with the inverse pan and tilt options.

DMX addressing is limited to make it impossible to set the DMX address so high that you are left without enough control channels for the fixture.

To set the fixture's DMX address:

1. Press Menu to open the main menu. Scroll to **DMX SETUP**.
2. Press Enter to enter the **DMX ADDRESS** menu, then scroll to the desired address and press Enter to save.

DMX modes

The **CONTROL MODE** menu lets you set the MAC Ultra Performance to one of the two DMX operating modes, Basic and Extended:

- Basic mode offers 8-bit control of strobe, color wheel, gobo selection, animation wheel, frost, prism, iris and FX plus 16-bit control of dimmer, CMY color mixing, color temperature control, gobo indexing and rotation, animation wheel indexing and rotation, zoom, focus, pan and tilt.
- Extended mode includes all the functionality of Basic mode but adds 16-bit control of iris aperture and animation, framing blade angle and position for each of the four blades in the framing system, and framing module angle.

To set the fixture's DMX mode:

1. Press Enter to enter the main menu.
2. Scroll to **CONTROL MODE**, then press Enter. Scroll to select either **BASIC** or **EXTENDED**, then press Enter to save.
3. Press Menu to exit.

P3 video

The MAC Ultra Performance accepts video data using Martin's proprietary P3 video protocol that has been a well-established standard in the industry for over 10 years. It lets you send a video signal from a media server or other video source to P3-compliant creative LED fixtures and moving heads over Ethernet cable using Martin's reliable P3 data protocol.

The intuitive graphic user interface in Martin P3 controllers lets you visualize and set up a custom installation that can contain a huge number of fixtures in any kind of physical arrangement within a few minutes. Device identification is automatic. You can arrange devices on the monitor using drag-and-drop. Latency from video input to output on fixtures is extremely low, while there is no latency between fixtures as they are fully synchronized via the P3 protocol. If you use P3 you do not need to worry about IP addresses, as P3 does not use IP addresses or IP communication.

The P3 protocol will supply both DMX data and video pixel data to fixtures over a network cable. On the MAC Ultra Performance you can use the video pixel data to control the intensity and/or the color of the fixture's output with real-time control using the P3 Mix DMX channel.

RDM

The MAC Ultra Performance can communicate over standard DMX cable and over Art-Net and sACN Ethernet links using RDM (Remote Device Management) in accordance with ESTA's *American National Standard E1.20-2006*.

RDM is a bi-directional communications protocol for use in DMX512 control systems, it is the open standard for DMX512 device configuration and status monitoring.

The RDM protocol allows data packets to be inserted into a DMX512 data stream without affecting existing non-RDM equipment. It allows a console or dedicated RDM controller to send commands to and receive messages from specific fixtures.

Note that a firmware update can sometimes expand a fixture's RDM functionality. If this happens, the firmware release notes will give details.

RDM ID

Each fixture has a factory-set RDM UID (unique identification number) that makes it addressable and identifiable in RDM systems. The number can be found in the control panel **INFORMATION** menu under **RDM UID**.

Supported RDM PIDs

The fixture supports the standard RDM PIDs (Parameter IDs) required by ESTA plus manufacturer-specific PIDs that give a range of configuration options.

See the following tables.

Standard RDM Parameter IDs

GET allowed	SET allowed	RDM parameter IDs	Notes
Network Management			
		DISC_UNIQUE_BRANCH	
		DISC_MUTE	
		DISC_UN_MUTE	
Status Collection			
✓		QUEUED_MESSAGE	
✓		STATUS_MESSAGES	
✓		STATUS_ID_DESCRIPTION	
	✓	CLEAR_STATUS_ID	
RDM Information			
✓		SUPPORTED_PARAMETERS	
✓		PARAMETER_DESCRIPTION	
Product information			
✓		DEVICE_INFO	
✓		DEVICE_MODEL_DESCRIPTION	
✓		MANUFACTURER_LABEL	
✓	✓	DEVICE_LABEL	
✓	✓	FACTORY_DEFAULTS	
✓		SOFTWARE_VERSION_LABEL	
DMX Setup			
✓	✓	DMX_PERSONALITY	
✓		DMX_PERSONALITY_DESCRIPTION	
✓	✓	DMX_START_ADDRESS	
✓		SLOT DESCRIPTION	
Sensors			
✓		SENSOR_DEFINITION	
✓		SENSOR_VALUE	
Usage information			
✓		DEVICE_HOURS	
✓		DEVICE_POWER_CYCLES	
Display settings			
✓	✓	DISPLAY_INVERT	
✓	✓	DISPLAY_LEVEL	
Configuration			
✓	✓	PAN_INVERT	
✓	✓	TILT_INVERT	
Network configuration			
✓		LIST_INTERFACES	
✓		INTERFACE_LABEL	
✓		INTERFACE_HARDWARE_ADDRESS_TYPE1	
✓		IPV4_DHCP_MODE	
✓		IPV4_CURRENT_ADDRESS	
✓	✓	IPV4_STATIC_ADDRESS	
	✓	INTERFACE_APPLY_CONFIGURATION	

Control			
✓	✓	IDENTIFY_DEVICE	
	✓	RESET_DEVICE	
✓	✓	PERFORM_SELFTEST	
✓		SELF_TEST_DESCRIPTION	

Manufacturer-specific RDM Parameter IDs

GET allowed	SET allowed	RDM parameter IDs (slot 21-22)	Notes
		DMX protocol	
✓	✓	DMX_RESET_ENABLE	
		Fixture behavior	
✓	✓	EFFECT_SPEED	
✓	✓	EFFECT_SHORTCUT_ENABLE	
✓	✓	DISPLAY_ERRORS_ENABLE	
✓	✓	DIMMER_CURVE	
✓	✓	VIDEO_TRACKING	
✓	✓	FOCUS_TRACKING	
✓	✓	DISPLAY_AUTO_OFF	
✓	✓	HIBERNATION_MODE	
✓	✓	TUNGSTEN_MODE	
✓	✓	KEYLIGHT_CALIBRATION	Automatic - Manual - Off
		Pan/tilt	
✓	✓	PAN_TILT_SPEED	Standard - Fast - Smooth
✓	✓	PAN_TILT_LIMITATION_ENABLE	
✓	✓	PAN_LIMITATION_MINIMUM	
✓	✓	PAN_LIMITATION_MAXIMUM	
✓	✓	TILT_LIMITATION_MINIMUM	
✓	✓	TILT_LIMITATION_MAXIMUM	
	✓	PAN_TILT_LIMITATION_RESET	
		Fixture cooling	
✓	✓	FAN_MODE	
✓	✓	FAN_CLEAN	
		Fixture information	
✓	✓	FIXTURE_ID	
✓		SERIAL_NUMBER	

Fixture setup

The onboard control panel lets you configure the fixture using a range of fixture settings. Note that many of these settings are also available on the Control / settings DMX channel (see “Adjusting settings via DMX” on page 25).

Fixture ID

The fixture lets you set a four-digit ID number to ease identification of the fixtures in an installation. When a fixture is powered on for the first time, it displays its DMX address by default. As soon as you set an ID number other than **0** in **FIXTURE ID**, the fixture will display this ID number by default, and indicate **FIXTURE ID** in the display.

Personality

The **PERSONALITY** menu provides several options that let you customize the fixture for different applications:

- The **PAN/TILT** menu offers the following options:
 - **PAN INVERSE** and **TILT INVERSE** let you invert the direction of pan and tilt movement. This can be a fast way of setting symmetrical action in multiple fixtures with no need to reprogram cues.
 - **FOLLOWSPOT MODE** disables the pan and tilt motors so that you can move the head manually using the integrated handles on the back of the head.

Warning! *The head becomes hot during use. Make sure that it is impossible for operators to burn themselves.*

Note that:

- * If you enable followspot mode in the **PERSONALITY** menu (or by sending a command from the DMX controller on the Control/Settings channel), the fixture starts in **HOLD POSITION** mode (see below) to prevent the head from sinking under gravity. The followspot operator must release the head with a **TOGGLE HOLD POSITION** command (see below) before the head can be moved freely.

Be prepared for the head to move slightly when you enable followspot mode and the head begins to hold its position.

- * When you disable followspot mode, the fixture resets pan and tilt – be prepared for the head to move without warning. After the pan and tilt reset the head returns to its original position.
- * In followspot mode, the pan and tilt motors are completely disabled to give the smoothest head movement with maximum freedom, but you must support the head constantly while in followspot mode (unless you apply **TOGGLE HOLD POSITION** in the shortcuts menu as described below). If you let go of the handles, the head will sink under gravity to a tilt down position.

- Using the shortcuts menu that opens if you hold the MENU button pressed in for 2 - 3 seconds (see “Shortcuts” on page 13), a followspot operator can quickly put the fixture into followspot mode and also use the **TOGGLE HOLD POSITION** feature. Applying **TOGGLE HOLD POSITION** while the fixture is in followspot mode uses the pan and tilt motors to hold the head in its current position. This menu item lets the followspot operator quickly toggle between free head movement and static head position.
- **LIMIT PAN/TILT** lets you define minimum and maximum limits for pan and tilt angles so that you can install fixtures close to obstacles (such as other fixtures or trusses) with no risk of collision, so that the beam will only hit a certain area of a stage or set, or so that you can avoid the fixture shining into the eyes of the audience.

PAN MIN and **TILT MIN** set minimum limits for pan and tilt, and **PAN MAX** and **TILT MAX** likewise set maximum limits. The fixture’s pan and tilt movement will remain in a ‘safe zone’ within the limits that you set.

- * To set the limits using the control panel menus, go into the **LIMIT PAN/TILT** menu and enter the minimum and maximum limits for pan and tilt as the 16-bit values that you would use to move pan and tilt to those positions via DMX. The range of values available is -32767 to 32768.
- * To set the limits via DMX, move the head using the pan and tilt DMX channels to the position where you want to set minimum pan and tilt limits, then enable *Pan minimum* and *Tilt minimum* limits on the

Control/Settings DMX channel, sending values for at least 1 second to activate them. Use the same method to set the maximum pan and tilt limits.

Note that when you power the fixture off, the head may move under its own weight to a position that is outside its pan and tilt limits.

RESET PAN/TILT LIMITS sets the fixture to default pan and tilt limits that are suitable for mounting the fixture in a GT Pre-Rig truss using standard Martin half-coupler rigging clamps. If you install the fixture in this type of pre-rig truss, you only need to execute a **RESET PAN/TILT LIMITS** command and set **LIMIT ENABLE** to **ON** to avoid the risk of head collisions.

- The **SPEED** menu gives you two movement speed options:
 - **PAN/TILT SPEED** lets you set pan and tilt movement to **STANDARD** (suitable for general use) **FAST** (optimized for speed) or **SMOOTH** (optimized for smooth movement – useful for slow movements in long-throw applications).
 - **EFFECT SPEED** lets you set all the fixture's effects to **STANDARD** (suitable for general use), **FOLLOW P/T** (effects speed follows the speed set for pan/tilt), **FAST** (optimized for speed) or **SLOW** (optimized for smooth movement – useful for slow, gradual effects changes).
- **DIMMER CURVE** provides four dimming options (see Figure 6):
 - **LINEAR** – (optically linear) the increase in light intensity appears to be linear as DMX value is increased.
 - **SQUARE LAW** – light intensity control is finer at low levels and coarser at high levels.
 - **INV SQUARE LAW** – light intensity control is coarser at low levels and finer at high levels.
 - **S-CURVE** – light intensity control is finer at low levels and high levels and coarser at medium levels. This curve emulates the RMS voltage dimming characteristics of an incandescent lamp.

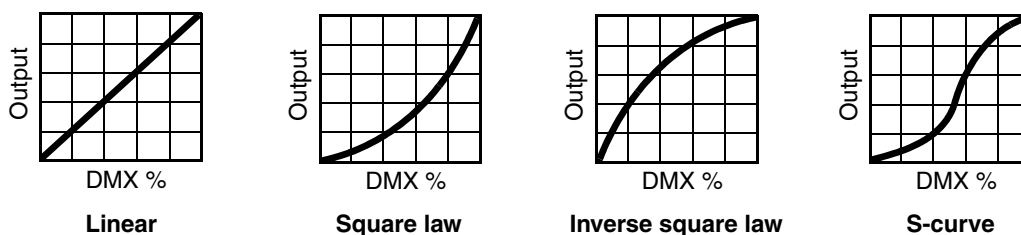

Figure 6: Dimming curve options

- **TUNGSTEN EMULATOR** gives the warm appearance and warm shift dimming characteristics of a tungsten lamp fixture.
- **FOCUS TRACKING** sets focus to automatically adjust to match the fixture's zoom angle. You can enable or disable focus tracking, and you can optimize this feature to give the best performance at far, medium or near projection distances.
- **VIDEO TRACKING** optimizes performance if the MAC Ultra Performance is used with a video source. In normal use, the fixture processes the signal it receives, tracking (or smoothing out) changes in values in order to ensure smooth fading between colors and/or intensities. This signal processing takes fractions of a second and is normally invisible, but if the fixture is used to display video the processing can interfere with video response times. If you enable video tracking, the fixture does not 'smooth out' input but instead snaps instantly when a value changes. If you enable video tracking, some lack of smoothness may be visible when dimming slowly via DMX at low intensity levels. When running in P3 Mixed Mode, where the video signal controls both the intensity and color of the output, you may notice that on very fast video content the CMY flags are unable to follow the fast changes while intensity is able to follow them. This may lead to white flashes with specific types of content. If you want to use very fast video content, we recommend that you use P3 Video Mode and control color via DMX instead of via P3. For best results, we recommend that you enable video tracking when using video as a source and disable it (the default setting) during DMX control.
- **DMX RESET** lets you reduce the risk of accidentally sending a reset command via DMX that might cause an unwanted blackout and/or unwanted light output in the middle of a show, for example, that will take several seconds to recover from.

- **EFFECT SHORTCUTS** determines whether the color and gobo wheels take the shortest path between two positions (shortcuts enabled), crossing the open position if necessary, or always avoid the open position (shortcuts disabled).
- **COOLING MODE** lets you select between five cooling fan options:
 - **CONSTANT FAN FULL** optimizes cooling fan operation for the lowest possible temperature by setting cooling fans to run constantly at full speed. Light output intensity is reduced if necessary to prevent the fixture from exceeding its maximum operating temperature during full speed fan operation.
 - **CONSTANT FAN MEDIUM** sets cooling fans to run constantly at medium speed. Light output intensity is reduced if necessary to prevent the fixture from exceeding its maximum operating temperature during medium speed fan operation.
 - **CONSTANT FAN LOW** sets cooling fans to run constantly at low speed. Light output intensity is reduced if necessary to prevent the fixture from exceeding its maximum operating temperature during low speed fan operation.
 - **CONSTANT FAN ULOW (ULTRALOW)** optimizes cooling fan operation for the lowest possible noise by setting cooling fans to run constantly at ultra-low speed. Light output intensity is reduced if necessary to prevent the fixture from exceeding its maximum operating temperature during ultra-low speed fan operation.
 - **REGULATED FANS** adjusts cooling fan operation to balance the fixture's noise and light output characteristics. Cooling fans are set to the lowest speed possible and then increased as fixture operating temperature rises. If the fixture reaches maximum operating temperature and full-speed fan operation is not enough to control fixture temperature, light output intensity is limited to keep the fixture within its operating temperature range.

Because the MAC Ultra Performance adjusts the maximum possible output intensity level as a function of fixture temperature, the choice of cooling mode will affect the maximum intensity level available. The exact level will vary depending on factors such as ambient temperature, airflow in the installation etc., but to give an approximate indication, you can expect to obtain the following intensity levels in the fixture's different cooling modes relative to the CONSTANT FAN FULL mode:

- REGULATED FANS: 93%
- CONSTANT FAN ULOW: 72%
- CONSTANT FAN LOW: 96%
- CONSTANT FAN MEDIUM: 99%
- CONSTANT FAN FULL: 100%

- **GOBO CT CORRECTION** provides an automatic color temperature correction using the CMY flags when a gobo is inserted into the beam. This counters the typical color temperature shift seen on LED-based fixtures when inserting a gobo. When this feature is not active, you will see a slight decrease in color temperature when inserting a gobo, as with other fixtures on the market.
Gobo CT Correction is enabled by default.
- **KEYLIGHT CALIBRATION** is achieved by adding a small amount of CMY to the spectral enhancement filter and/or the CTO filter in order to give the most consistent white in multiple fixtures. Values for the amount of cyan, magenta and yellow added are set at the factory, and the calibration data is stored in the fixture. Replacing either of these filters with a new item may result in a slight shift in color temperature or spectral enhancement characteristics compared to other fixtures, but the keylight calibration function lets you recalibrate the fixture and eliminate any inconsistency.
In firmware version 1.5.0, keylight calibration can be toggled between Automatic, Manual and Disabled via the standard user control menus, the DMX Control and Settings channel, RDM or P3.
 - **AUTOMATIC** uses the keylight calibration values programmed during the original calibration process at the factory.
 - **MANUAL** uses the custom keylight calibration values programmed on the Control / Settings DMX channel (see "Adjusting keylight calibration via DMX" on page 26).
 - **DISABLED** disables all factory and custom calibration adjustments for the spectral enhancement filter and CTO filter – no CMY is added to the output when using one of these filters.
- **DISPLAY** offers the following options for the LCD display:
 - **DISPLAY SLEEP** sets the fixture display to black out a certain period after the last key press on the fixture's control panel. If ERROR MODE (see below) is set to NORMAL, the display will light up again if the fixtures detects and error.

- **DISPLAY INTENSITY** lets you adjust the brightness of the display backlighting by setting the intensity to a level from 10% to 100%.
- **DISPLAY ROTATION** rotates the display manually through 180° so that it can be read easily no matter how the fixture is oriented.
- **TEMPERATURE UNIT** lets you choose whether the fixture should display all temperature readings in Celsius or Fahrenheit.
- **ERROR MODE** enables or disables error warnings.
 - If set to **NORMAL**, the display is activated and lights up if the fixture needs to report an error.
 - If set to **SILENT**, the fixture does not light the display with error warnings but error messages can still be read when the display is activated manually.

In both **NORMAL** and **SILENT** modes, the status LED lights amber to indicate a warning and red to indicate an error.
- **HIBERNATION MODE** sets light output intensity to zero and disables effect deployment and pan/tilt movement. The main purpose of the mode is to protect the fixture from the intake of airborne material such as dust and confetti and to provide an option for situations where noise is critical. The small reduction in power consumption obtained in Hibernation Mode is not the main purpose of this mode. When you bring the fixture out of hibernation mode, it performs a full reset.
- **SCENE CAPTURE** lets you capture all the DMX values that the fixture is currently receiving and save them as a scene. If you enable **PLAYBACK**, the fixture will show that scene every time it is powered on or you carry out a reset.
 - If the fixture receives a DMX control signal during playback, it will immediately stop showing its saved scene. If the fixture is powered off and on again or if the fixture is reset, it will again show its saved scene.
 - To stop the fixture showing its saved scene at each power cycle or reset, set **PLAYBACK** to **DISABLE** in the **SCENE CAPTURE** menu or on the DMX Control / Settings channel.

Managing fixture settings

Factory default settings

FACTORY DEFAULT lets you reload the fixture's factory default settings. Effect calibration settings are not affected, so any changes you have made to zoom, pan and tilt offsets will be kept.

Custom settings

The custom configuration function **CUSTOM 1 - CUSTOM 3** allows you to save and recall up to three sets of fixture settings. These include all the settings in the **PERSONALITY** menu as well as the fixture's DMX address.

Fixture information readouts

The following fixture information can be called up in the display:

- **POWER ON TIME** provides two counters, one user-resettable, one non-resettable, that display the total number of hours the fixture has been powered on since manufacture.
- **POWER ON CYCLES** provides two counters, one user-resettable, one non-resettable, that display the total number of power on/off cycles since manufacture.
- **SW VERSION** displays the currently installed firmware (fixture software) version.
- **RDM UID** displays the fixture's factory-set unique ID for identification in RDM systems.
- **FAN SPEEDS** provides separate status readouts from the fixture's cooling fans.

Temperatures

The **TEMPERATURES** menu provides separate temperature readouts for each of the fixture's PCBs. You can choose to see the current readout or the minimum and maximum temperature levels since the fixture was last powered on.

DMX signal monitoring

The MAC Ultra Performance provides data on the DMX signal it is receiving in the **DMX LIVE** menu. This information can be useful for troubleshooting control problems.

- **RATE** displays the DMX refresh rate in packets per second. Values lower than 10 or higher than 44 may result in erratic performance, especially when using tracking control.
- **QUALITY** displays the quality of the received DMX data as a percentage of usable packets from the data received. Values much below 100 indicate interference, poor connections, or other problems with the serial data link that are the most common cause of control problems.
- **START CODE** displays the DMX start code. Packets with a start code other than 0 may cause irregular performance.

The **DMX LIVE** menu lets you scroll through all the fixture's DMX channels and display the DMX values from 0 - 255 that are being received on each channel.

Test sequences

The **FIXTURE TEST** menu lets you test:

- all the fixture's effects
- dimming functionality
- each individual mechanical effect, or
- pan and tilt only.

Before you run a test, prepare for the head to move and the fixture to light up suddenly without warning.

To run a test:

- In the **FIXTURE TEST** menu, scroll to **TEST ALL**, **TEST LEADS**, **TEST EFFECTS** or **TEST PAN/TILT** and press ENTER.
- In the **TEST EFFECTS** menu, scroll to the effect you want to test and press ENTER to start a test sequence for that effect.
- In the **TEST PAN/TILT** menu, choose **PAN** or **TILT**, make sure that the fixture base is held securely and that there is no danger of the fixture falling over or head colliding, then press ENTER to start the test sequence.
- Press MENU to stop the test sequence.

Manual control

The **MANUAL CONTROL** menu lets you reset the fixture and operate it without a DMX controller.

To execute commands in the **MANUAL CONTROL** menu, select the effect that you want to control, then enter a value from 0 to 255 for 8-bit commands or 0 to 65536 for 16-bit commands to apply that command. The menu items and values available correspond to the commands listed in the DMX protocol in this User Manual.

When you exit the **MANUAL CONTROL** menu, the fixture will keep its effect positions and settings until you enter a new menu. When you do this, the fixture will revert to default positions and settings. The fixture will also revert to default positions and settings if you exit and then re-enter **MANUAL CONTROL**.

Service

Servicing the fixture and the contents of the **SERVICE** menu are covered in the MAC Ultra Performance Safety and Installation Manual supplied with fixtures and available for download from the product pages on the Martin website at www.martin.com.

Module and fixture calibration

Fixtures are calibrated at the factory when the light engine, CMY module and effect module (color wheel effects module) are installed. We therefore recommend that you keep the original modules with the fixture if you disassemble the fixture for service. If you swap modules from one fixture to another, the fixtures may need to be recalibrated in order to maintain consistent color characteristics across different fixtures. A small label indicating the type and serial number of the original fixture is fixed to each module at the factory to help you keep modules together with their original fixture.

Adjusting settings via DMX

Certain fixture settings and parameters can be adjusted from the DMX controller on Channel 42, the Fixture Control/Settings channel. Commands sent on this channel override any settings entered in the fixture's onboard control menus.

To help you avoid accidentally applying a setting that may disrupt a light show, for example, the commands must be held for a certain time before they are applied. For example, the command that turns off the display illumination must be held for one second to activate it. The command that resets the fixture must be held for five seconds to activate it. The DMX protocol table in this user manual gives details of times required.

Resetting

Either the entire fixture or individual effects can be reset to their initial positions. Resetting individual effects can allow on-the-fly recovery if an effect loses its correct position, for example, without having to reset the entire fixture.

Illuminating the display

You can set the fixture's display panel to ON or OFF with a DMX command. This makes it possible to read the fixture's DMX address while the fixture is installed in the rig but black out the display panel during a show.

If the display is set to ON via DMX, it will enter sleep mode and black out after a short period of inactivity. To bring it out of sleep mode, set the display to ON again via DMX.

Control menu setting overrides

The following fixture settings can be adjusted via DMX, overriding the settings entered in the onboard control menus. See under "DMX protocol" on page 27 for details of these settings.

- Dimming curve
- Tungsten emulation
- Pan and tilt speed
- Effect shortcuts, also called parameter shortcuts (effects take shortest route when changing, even if this means crossing the open position)
- Focus tracking
- Video tracking
- Fan speed

It is also possible to adjust calibration offsets via DMX. This feature can be useful if you want to fine-tune pan, tilt or other effects after fixtures have been installed in a lighting rig, for example.

Adjusting calibration offsets via DMX

You can adjust the home positions of pan, tilt and all the fixture's effects remotely via DMX by setting custom calibration offsets on the Control/Settings DMX channel.

To set a custom offset in the position of an effect:

1. Set the effect to a specific value via DMX (for example, set all the fixtures in a group to DMX value 200 on the zoom channel).
2. Select 'Enable calibration adjustment' on the Control/Settings channel and hold for 5 seconds to activate.
3. The fixture now registers the current positions of all effects and holds them there. To select an effect to adjust, you must first release it from its hold position by changing the value on its DMX channel by +/- 10%. The effect then returns to its hold position. The effect's DMX channel now represents the full

calibration range. The range can vary but is typically +/- 5-10%. In this case you can adjust the effect's position using that effect's DMX channel (8 or 16 bit) as follows:

- DMX value 0 = -5%
 - DMX value 127/32767 = 0%
 - DMX value 255/65535 = +5%.
4. Adjust the effect until it is in the required position (for example, adjust the zoom angle on each fixture in the group until the angle on all fixtures is identical – this is the position that you will obtain when you send DMX value 200).
 5. Send a 'Store XXX calibration' command on the Control/Settings channel for each effect that you adjust and hold that command for 5 seconds to activate. The new calibration offset is now stored in memory.
 6. When you have finished adjusting calibration offsets, send value 0 on the Control/Settings channel and hold for 5 seconds to exit the DMX calibration procedure and return to normal DMX control.

Calibration offsets that are stored in memory are not affected by powering the fixture off and on or by updating the fixture software.

Restoring default calibration offsets

If you want to delete all custom calibration offsets and return the offsets to their default values:

1. On the Control/Settings DMX channel, send a 'Return all calibration settings to factory defaults' command and hold for 5 seconds.
2. The fixture will return all effects to their default calibration values.

Note that, If you have overwritten the factory default values by applying a SERVICE → CALIBRATION → SAVE DEFAULTS command in the fixture's onboard control panel, the fixture will return to the calibration values that were saved as the default values at that time. The SAVE DEFAULTS command in the fixture's control panel permanently replaces the factory default calibration settings with the current custom calibration settings.

Adjusting keylight calibration via DMX

Recalibration may become necessary to keep the keylight characteristics of multiple fixtures consistent if you replace the color temperature or spectral enhancement filter with a new one. See also the point KEYLIGHT SETTINGS on page 21.

Adjusting keylight calibration involves setting the amount of Cyan, Magenta and Yellow that is added to the CTO or spectral enhancement filter in order to fine-tune the output characteristics across multiple fixtures. You carry out these adjustments remotely via DMX.

To adjust the keylight calibration settings in multiple fixtures:

1. Apply power to the fixtures that you want to calibrate and aim them at an even white surface.
2. On each fixture, go to the Control / Settings DMX channel (Ch. 42), and hold the DMX value required for **Start CTO keylight calibration** or **Start spectral enhancement keylight calibration** for 5 seconds. The fixture will engage the CTO or spectral enhancement filter and set CMY to 0%.
3. On each fixture's CMY channels, adjust the CMY values until the output of all fixtures looks the same.
4. On the Control / Settings channel, hold the DMX value required for **Store CTO keylight calibration** or **Store spectral enhancement keylight calibration** for 5 seconds.

The fixture will now behave as follows:

- When keylight calibration is used in MANUAL mode, it will use the custom values stored using the above procedure.
- When keylight calibration is used in AUTOMATIC mode, it will use the values stored during the original calibration procedure at the factory.

DMX protocol

Basic Mode

MAC Ultra Performance firmware version 1.5.0.

Channel	DMX Value	Function	Fade type	Default value
Strobe / Intensity				
1	0 - 19	Shutter closed	Snap	30
	20 - 49	Shutter open		
	50 - 200	Strobe, slow → fast		
	201 - 210	Shutter open		
	211 - 255	Random strobe, slow → fast		
2	0 - 65535	Dimmer (16-bit)	Fade	0
3		Closed → open		
Color				
4	0 - 65535	Cyan (16-bit)	Fade	0
5		0 → 100%		
6	0 - 65535	Magenta (16-bit)	Fade	0
7		0 → 100%		
8	0 - 65535	Yellow (16-bit)	Fade	0
9		0 → 100%		
10	0 - 65535	CTC (16-bit)	Fade	0
11		0 → 100%		
12		Color wheel	Snap	0
		Indexing		
	0	<i>Split colors (continuous color wheel indexing)</i> Open		
	1 - 14	Open → Color 1		
	15	Color 1 (Spectral enhancement)		
	16 - 29	Color 1 → Color 2		
	30	Color 2 (Blue)		
	31 - 44	Color 2 → Color 3		
	45	Color 3 (Deep Green)		
	46 - 59	Color 3 → Color 4		
	60	Color 4 (Orange)		
	61 - 74	Color 4 → Color 5		
	75	Color 5 (Navy Blue)		
	76 - 89	Color 5 → Color 6		
	90	Color 6 (Deep Red)		
	91 - 104	Color 6 → Open		
	105 - 160	Open		
		<i>Solid colors</i>		
	161 - 163	Color 1 (Spectral enhancement)		
	164 - 166	Color 2 (Blue)		
	167 - 169	Color 3 (Deep Green)		
	170 - 172	Color 4 (Orange)		
173 - 175	Color 5 (Navy Blue)			
176 - 178	Color 6 (Deep Red)			
179 - 192	Open			
	Continuous rotation			
193 - 214	CW, fast → slow			
215 - 221	Stop (wheel stops at current position)			
222 - 243	CCW slow → fast			
	Random colors			
244 - 247	Fast			
248 - 251	Medium			
252 - 255	Slow			

Table 2: MAC Ultra Performance Basic Mode DMX Protocol

Channel	DMX Value	Function	Fade type	Default value
Gobos				
13	0 - 9	Gobo wheel 1 selection Gobo indexing (control angle on next channels) Open	Snap	0
	10 - 14	Gobo 1 (Time Ripples)		
	15 - 19	Gobo 2 (Look Sharper)		
	20 - 24	Gobo 3 (Compass)		
	25 - 29	Gobo 4 (Deep Space)		
	30 - 34	Gobo 5 (Radar)		
		Gobo rotation (control direction and speed on next channels)		
	35 - 39	Gobo 1		
	40 - 44	Gobo 2		
	45 - 49	Gobo 3		
	50 - 54	Gobo 4		
	55 - 59	Gobo 5		
		Gobo shake		
60 - 89	Gobo 1 shake slow 360° → fast 10°			
90 - 119	Gobo 2 shake slow 360° → fast 10°			
120 - 149	Gobo 3 shake slow 360° → fast 10°			
150 - 179	Gobo 4 shake slow 360° → fast 10°			
180 - 209	Gobo 5 shake slow 360° → fast 10°			
210 - 255	No function			
14	0- 65535	Gobo wheel 1 indexed position/rotation (16-bit) Gobo indexing Indexed position, 0° at 32768	Fade	32768
15	0 - 600 601 - 32130 32131 - 32895 32896 - 64515 64516 - 65535	Gobo rotation Stop, gobo indexed at 0° Gobo rotation CW fast → slow Stop, gobo stops at current position Gobo rotation CCW slow → fast Stop, gobo indexed at 90°		
16	0 - 9	Gobo wheel 2 selection Gobo indexing (control angle on next channels) Open	Snap	0
	10 - 14	Gobo 1 (String Theory)		
	15 - 19	Gobo 2 (Hazy Waves)		
	20 - 24	Gobo 3 (Limbo)		
	25 - 29	Gobo 4 (Up Is Down)		
	30 - 34	Gobo 5 (Brush Up)		
		Gobo rotation (control direction and speed on next channels)		
	35 - 39	Gobo 1		
	40 - 44	Gobo 2		
	45 - 49	Gobo 3		
	50 - 54	Gobo 4		
	55 - 59	Gobo 5		
		Gobo shake		
60 - 89	Gobo 1 shake slow 360° → fast 10°			
90 - 119	Gobo 2 shake slow 360° → fast 10°			
120 - 149	Gobo 3 shake slow 360° → fast 10°			
150 - 179	Gobo 4 shake slow 360° → fast 10°			
180 - 209	Gobo 5 shake slow 360° → fast 10°			
210 - 255	No function			
17	0- 65535	Gobo wheel 2 indexed position/rotation (16-bit) Gobo indexing Indexed position, 0° at 32768	Fade	32768
18	0 - 600 601 - 32130 32131 - 32895 32896 - 64515 64516 - 65535	Gobo rotation Stop, gobo indexed at 0° Gobo rotation CW fast → slow Stop, gobo stops at current position Gobo rotation CCW slow → fast Stop, gobo indexed at 90°		
19	0 - 5	Animation wheel indexing /rotation Open	Snap	0
	6 - 10	Horizontal position indexed		
	11 - 15	Horizontal position rotation		
	16 - 20	Vertical position rotation		
	21 - 25	Vertical position indexed		
	26 - 110	Angled position rotation		
	111 - 195	Angled position vertical index		
	196 - 255	Angled position horizontal index		

Table 2: MAC Ultra Performance Basic Mode DMX Protocol

Channel	DMX Value	Function	Fade type	Default value
20	0 - 255	Animation wheel indexed position/rotation speed Indexed position Position, min. → max.	Fade	128
	0 - 2	Rotation speed and direction Stop, indexed at 0°		
	3 - 126	Continuous rotation CW fast → slow		
	127 - 129	Stop, wheel stops at current position		
	130 - 253	Continuous rotation CCW slow → fast		
254 - 255	Stop, indexed at 90°			
21	0 - 255	Frost No frost → full frost	Fade	0
22	0 - 10	Prism indexing/rotation Open	Snap	0
	11 - 138	Indexed position		
	139 - 255	Rotation		
23	0 - 255	Prism indexed position/rotation speed Indexed position Position, min. → max. (128 = index 0°)	Fade	128
	0 - 2	Rotation speed and direction Stop, indexed at 0°		
	3 - 126	Continuous rotation CW fast → slow		
	127 - 129	Stop, prism stops at current position		
	130 - 253	Continuous rotation CCW slow → fast		
254 - 255	Stop, indexed at 45°			
24	0 - 200	Iris Open → closed	Fade	0
	201 - 225	Animate fast → slow		
	226 - 230	Iris stops at current position		
	231 - 255	Animate reverse slow → fast		
Zoom / Focus				
25	0 - 65535	Zoom (16-bit) Wide → narrow	Fade	32768
26				
27	0 - 65535	Focus (16-bit) Infinity → near	Fade	32768
28				
Framing				
29	0 - 255	Framing blade 1 (top): position Out → in	Fade	0
30	0 - 126	Framing blade 1: angle Angle –	Fade	128
	127 - 128	Parallel		
	129 - 255	Angle +		
31	0 - 255	Framing blade 2 (right-hand): position Out → in	Fade	0
32	0 - 126	Framing blade 2: angle Angle –	Fade	128
	127 - 128	Parallel		
	129 - 255	Angle +		
33	0 - 255	Framing blade 3 (bottom): position Out → in	Fade	0
34	0 - 126	Framing blade 3: angle Angle –	Fade	128
	127 - 128	Parallel		
	129 - 255	Angle +		
35	0 - 255	Framing blade 4 (left-hand): position Out → in	Fade	0
36	0 - 126	Framing blade 4: angle Angle –	Fade	128
	127 - 128	Parallel		
	129 - 255	Angle +		

Table 2: MAC Ultra Performance Basic Mode DMX Protocol

Channel	DMX Value	Function	Fade type	Default value
37	0 -126	Framing module angle	Fade	128
	127 - 128	Angle – Parallel		
	129 - 255	Angle +		
Movement				
38	0 - 65535	Pan (16-bit)	Fade	32768
39		Left → right		
40	0 - 65535	Tilt (16-bit)	Fade	32768
41		Forward → backward		
Control / Settings				
42		Fixture control/settings <i>(hold for number of seconds indicated to activate)</i>	Snap	0
	0 - 9	Exit calibration adjustment and return to normal control – 5 sec.		
	10 - 14	Reset entire fixture – 5 sec.		
	15	No function		
	16	Reset color – 5 sec.		
	17	Reset beam only – 5 sec.		
	18	Reset pan and tilt only – 5 sec.		
	19 - 22	No function		
	23	Linear dimming curve – 1 sec. (menu override, setting unaffected by power off/on)		
	24	Square law dimming curve – 1 sec. (menu override, default setting, setting unaffected by power off/on)		
	25	Inverse square law dimming curve – 1 sec. (menu override, setting unaffected by power off/on)		
	26	S-curve dimming curve – 1 sec. (menu override, setting unaffected by power off/on)		
	27	Standard pan and tilt speed – 1 sec. (default setting)		
	28	Fast pan and tilt – 1 sec. (menu override - setting returns to <i>Standard pan and tilt speed</i> after power on/off)		
	29	Smooth pan and tilt – 1 sec. (menu override - setting returns to <i>Standard pan and tilt speed</i> after power on/off)		
	30	Effect shortcuts on (default setting)		
	31	Effect shortcuts off		
	32	Disable focus tracking – 1 sec.		
	33	Focus tracking = Near distance – 1 sec.		
	34	Focus tracking = Medium distance (default setting) – 1 sec.		
	35	Focus tracking = Far distance – 1 sec.		
	36	Enable video tracking		
	37	Disable video tracking (default setting)		
	38 - 51	No function		
	52	Control panel display on (default setting) – 1 sec.		
	53	Control panel display off – 1 sec.		
	54	Regulated fan speed, fixed light output intensity (default setting) – 1 sec.		
	55	Full fan speed, regulated light output intensity – 1 sec.		
	56	Medium fan speed, regulated light output intensity – 1 sec.		
	57	Low fan speed, regulated light output intensity – 1 sec.		
	58	Ultra-low fan speed, regulated light output intensity – 1 sec.		
	59 - 60	No function		
	61	Hibernation mode on – 1 sec.		
62	Hibernation mode off – 1 sec.			
63	Followspot mode on – 5 sec.			
64	Followspot mode off (default setting) – 5 sec.			
65	Pan and tilt limits on – 1 sec.			
66	Pan and tilt limits off (default setting) – 1 sec.			
67	Pan limit low – 1 sec.			
68	Pan limit high – 1 sec.			
69	Tilt limit low – 1 sec.			
70	Tilt limit high – 1 sec.			
71	Reset pan and tilt limits – 1 sec.			

Table 2: MAC Ultra Performance Basic Mode DMX Protocol

Channel	DMX Value	Function	Fade type	Default value
42 contd.	72	Tungsten emulation on – 1 sec.	Snap	0
	73	Tungsten emulation off (default setting) – 1 sec.		
	74	Scene capture record – 5 sec.		
	75	Scene capture playback on – 5 sec.		
	76	Scene capture playback off (default setting) – 5 sec.		
	77 - 78	<i>No function</i>		
	79	Gobo CT correction on (default setting) – 1 sec.		
	80	Gobo CT correction off – 1 sec.		
	81 - 86	<i>No function</i>		
	87	Keylight calibration disabled – 1 sec.		
	88	Keylight calibration manual – 1 sec.		
	89	Keylight calibration automatic (default setting) – 1 sec.		
	90 - 99	<i>No function</i>		
	100	Enable calibration adjustment – 5 sec.		
	101	Store pan and tilt calibration – 5 sec.		
	102	Store dimmer calibration – 5 sec.		
	103	Store Cyan calibration – 5 sec.		
	104	Store Magenta calibration – 5 sec.		
	105	Store Yellow calibration – 5 sec.		
	106	Store CTC calibration – 5 sec.		
	107	Store all CMYC calibration – 5 sec.		
	108	Store rotating gobo wheel 1 calibration – 5 sec.		
	109	Store rotating gobo wheel 2 calibration – 5 sec.		
	110	Store animation wheel calibration – 5 sec.		
	111	Store framing system calibration – 5 sec.		
	112	Store iris calibration – 5 sec.		
	113	Store focus calibration – 5 sec.		
	114	Store zoom calibration – 5 sec.		
	115	Store color wheel calibration – 5 sec.		
	116 - 193	<i>No function</i>		
	194	Start CTO keylight calibration – 5 sec.		
195	Start spectral enhancement keylight calibration – 5 sec.			
196	Store CTO keylight enhancement keylight calibration – 5 sec.			
197	Store spectral enhancement keylight calibration – 5 sec.			
198	Store all calibration settings (except keylight settings) – 5 sec.			
199	Return all calibration settings (except keylight settings) to factory defaults – 5 sec.			
200 - 255	<i>No function</i>			
P3 Mix				
43	0 - 26	P3 Mix <i>DMX Mode</i> Intensity and colors fully controlled by DMX, P3 pixel data ignored	Snap	0
	27 - 228	<i>Mixed Mode</i> Cross-fade from DMX control of intensity and colors to P3 control of intensity and colors: <ul style="list-style-type: none"> At 27, intensity and colors are still fully controlled by DMX. Between 27 and 228, you mix/crossfade from DMX to P3 control. At 228, the Intensity of each of the 10 x Animation segments is controlled by 10 x separate P3 pixels and color is controlled by P3 Pixel 1 (the black pixel on the P3 map). 		
	229 - 255	<i>Video Mode</i> Intensity of 10 x Animation segments controlled by P3, color controlled by DMX (DMX channels 'color' the P3 pixel data)		
Pre-programmed FX				
44	0	FX1 selection (see FX table on page 40) No effect	Snap	0
	1 - 254	Effect selection (adjust speed and direction on channel 45)		
	255	Enable PWM frequency adjustment (adjust frequency on channel 45)		
45	0 - 126	FX1 speed and direction Effect reversed fast → slow	Fade	128
	127 - 129	Effect stops		
	130 - 255	Effect forward slow → fast		

Table 2: MAC Ultra Performance Basic Mode DMX Protocol

Channel	DMX Value	Function	Fade type	Default value
46	0	FX2 selection (see FX table on page 40) No effect	Snap	0
	1 - 159	Effect selection (adjust speed and direction on channel 47)		
	160	Enable FX1 y-axis control on channel 47		
	161 - 194	<i>No function (these FX are available for FX1 only)</i>		
	195 - 254	Effect selection (adjust speed and direction on channel 47)		
47	255	Enable PWM frequency adjustment (adjust frequency on channel 47)	Fade	128
	0 - 126	FX2 speed and direction Effect reversed fast → slow		
	127 - 129	Effect stops		
48	130 - 255	Effect forward slow → fast	Snap	36
	0	FX synchronization No sync		
	1	Offset shift 10°		
	2	Offset shift 20°		
	3	Offset shift 30°		
	4	Offset shift 40°		
	5	Offset shift 50°		
	6	Offset shift 60°		
	7	Offset shift 70°		
	8	Offset shift 80°		
	9	Offset shift 90°		
	10	Offset shift 100°		
	11	Offset shift 110°		
	12	Offset shift 120°		
	13	Offset shift 130°		
	14	Offset shift 140°		
	15	Offset shift 150°		
	16	Offset shift 160°		
	17	Offset shift 170°		
	18	Offset shift 180°		
	19	Offset shift 190°		
	20	Offset shift 200°		
	21	Offset shift 210°		
	22	Offset shift 220°		
	23	Offset shift 230°		
	24	Offset shift 240°		
	25	Offset shift 250°		
	26	Offset shift 260°		
	27	Offset shift 270°		
	28	Offset shift 280°		
29	Offset shift 290°			
30	Offset shift 300°			
31	Offset shift 310°			
32	Offset shift 320°			
33	Offset shift 330°			
34	Offset shift 340°			
35	Offset shift 350°			
36	Synchronized: all fixtures start FX cycles at same time			
37 - 100	<i>No function</i>			
101 - 120	Random start (Channel 45 controls overall speed)			
121 - 140	Random duration			
141 - 255	<i>No function</i>			

Table 2: MAC Ultra Performance Basic Mode DMX Protocol

Extended Mode

MAC Ultra Performance firmware version 1.5.0.

Channel	DMX Value	Function	Fade type	Default value
Strobe / Intensity				
1	0 - 19	Strobe/shutter effect Shutter closed Shutter open Strobe, slow → fast Shutter open Random strobe, slow → fast	Snap	30
	20 - 49			
	50 - 200			
	201 - 210			
	211 - 255			
2	0 - 65535	Dimmer (16-bit)	Fade	0
3		Closed → open		
Color				
4	0 - 65535	Cyan (16-bit)	Fade	0
5		0 → 100%		
6	0 - 65535	Magenta (16-bit)	Fade	0
7		0 → 100%		
8	0 - 65535	Yellow (16-bit)	Fade	0
9		0 → 100%		
10	0 - 65535	CTC (16-bit)	Fade	0
11		0 → 100%		
12		Color wheel Indexing	Snap	0
	0	<i>Split colors (continuous color wheel indexing)</i> Open		
	1 - 14	Open → Color 1		
	15	Color 1 (Spectral enhancement)		
	16 - 29	Color 1 → Color 2		
	30	Color 2 (Blue)		
	31 - 44	Color 2 → Color 3		
	45	Color 3 (Deep Green)		
	46 - 59	Color 3 → Color 4		
	60	Color 4 (Orange)		
	61 - 74	Color 4 → Color 5		
	75	Color 5 (Navy Blue)		
	76 - 89	Color 5 → Color 6		
	90	Color 6 (Deep Red)		
	91 - 104	Color 6 → Open		
	105 - 160	Open		
		<i>Solid colors</i>		
	161 - 163	Color 1 (Spectral enhancement)		
	164 - 166	Color 2 (Blue)		
	167 - 169	Color 3 (Deep Green)		
170 - 172	Color 4 (Orange)			
173 - 175	Color 5 (Navy Blue)			
176 - 178	Color 6 (Deep Red)			
179 - 192	Open			
	Continuous rotation			
193 - 214	CW, fast → slow			
215 - 221	Stop (wheel stops at current position)			
222 - 243	CCW slow → fast			
	Random colors			
244 - 247	Fast			
248 - 251	Medium			
252 - 255	Slow			

Table 3: MAC Ultra Performance Extended Mode DMX Protocol

Channel	DMX Value	Function	Fade type	Default value
Gobos				
13	0 - 9	Gobo wheel 1 selection Gobo indexing (control angle on next channels) Open	Snap	0
	10 - 14	Gobo 1 (Time Ripples)		
	15 - 19	Gobo 2 (Look Sharper)		
	20 - 24	Gobo 3 (Compass)		
	25 - 29	Gobo 4 (Deep Space)		
	30 - 34	Gobo 5 (Radar)		
		Gobo rotation (control direction and speed on next channels)		
	35 - 39	Gobo 1		
	40 - 44	Gobo 2		
	45 - 49	Gobo 3		
	50 - 54	Gobo 4		
	55 - 59	Gobo 5		
		Gobo shake		
60 - 89	Gobo 1 shake slow 360° → fast 10°			
90 - 119	Gobo 2 shake slow 360° → fast 10°			
120 - 149	Gobo 3 shake slow 360° → fast 10°			
150 - 179	Gobo 4 shake slow 360° → fast 10°			
180 - 209	Gobo 5 shake slow 360° → fast 10°			
210 - 255	No function			
14	0- 65535	Gobo wheel 1 indexed position/rotation (16-bit) Gobo indexing Indexed position, 0° at 32768	Fade	32768
15	0 - 600 601 - 32130 32131 - 32895 32896 - 64515 64516 - 65535	Gobo rotation Stop, gobo indexed at 0° Gobo rotation CW fast → slow Stop, gobo stops at current position Gobo rotation CCW slow → fast Stop, gobo indexed at 90°		
16	0 - 9	Gobo wheel 2 selection Gobo indexing (control angle on next channels) Open	Snap	0
	10 - 14	Gobo 1 (String Theory)		
	15 - 19	Gobo 2 (Hazy Waves)		
	20 - 24	Gobo 3 (Limbo)		
	25 - 29	Gobo 4 (Up Is Down)		
	30 - 34	Gobo 5 (Brush Up)		
		Gobo rotation (control direction and speed on next channels)		
	35 - 39	Gobo 1		
	40 - 44	Gobo 2		
	45 - 49	Gobo 3		
	50 - 54	Gobo 4		
	55 - 59	Gobo 5		
		Gobo shake		
60 - 89	Gobo 1 shake slow 360° → fast 10°			
90 - 119	Gobo 2 shake slow 360° → fast 10°			
120 - 149	Gobo 3 shake slow 360° → fast 10°			
150 - 179	Gobo 4 shake slow 360° → fast 10°			
180 - 209	Gobo 5 shake slow 360° → fast 10°			
210 - 255	No function			
17	0- 65535	Gobo wheel 2 indexed position/rotation (16-bit) Gobo indexing Indexed position, 0° at 32768	Fade	32768
18	0 - 600 601 - 32130 32131 - 32895 32896 - 64515 64516 - 65535	Gobo rotation Stop, gobo indexed at 0° Gobo rotation CW fast → slow Stop, gobo stops at current position Gobo rotation CCW slow → fast Stop, gobo indexed at 90°		
19	0 - 5	Animation wheel indexing /rotation Open	Snap	0
	6 - 10	Horizontal position indexed		
	11 - 15	Horizontal position rotation		
	16 - 20	Vertical position rotation		
	21 - 25	Vertical position indexed		
	26 - 110	Angled position rotation		
	111 - 195	Angled position vertical index		
	196 - 255	Angled position horizontal index		

Table 3: MAC Ultra Performance Extended Mode DMX Protocol

Channel	DMX Value	Function	Fade type	Default value
20	0 - 255	Animation wheel indexed position/rotation speed Indexed position Position, min. → max.	Fade	128
	0 - 2	Rotation speed and direction Stop, indexed at 0°		
	3 - 126	Continuous rotation CW fast → slow		
	127 - 129	Stop, wheel stops at current position		
	130 - 253	Continuous rotation CCW slow → fast		
	254 - 255	Stop, indexed at 90°		
21	0 - 255	Frost No frost → full frost	Fade	0
22	0 - 10	Prism indexing/rotation Open	Snap	0
	11 - 138	Indexed position		
	139 - 255	Rotation		
23	0 - 255	Prism indexed position/rotation speed Indexed position Position, min. → max. (128 = index 0°)	Fade	128
	0 - 2	Rotation speed and direction Stop, indexed at 0°		
	3 - 126	Continuous rotation CW fast → slow		
	127 - 129	Stop, prism stops at current position		
	130 - 253	Continuous rotation CCW slow → fast		
	254 - 255	Stop, indexed at 45°		
24	0 - 51400	Iris Open → closed	Fade	0
51401 - 57825	Animate fast → slow			
25	57826 - 59110	Iris stops at current position		
	59111 - 65535	Animate reverse slow → fast		
Zoom / Focus				
26	0 - 65535	Zoom (16-bit) Wide → narrow	Fade	32768
27				
28	0 - 65535	Focus (16-bit) Infinity → near	Fade	32768
29				
Framing				
30	0 - 65535	Framing blade 1 (top): position Out → in	Fade	0
31				
32	0 - 32766	Framing blade 1 (top): angle Angle –	Fade	32768
33	32767 - 32768	Parallel		
	32769 - 65535	Angle +		
34	0 - 65535	Framing blade 2: (right-hand) position Out → in	Fade	0
35				
36	0 - 32766	Framing blade 2:(right-hand) angle Angle –	Fade	32768
37	32767 - 32768	Parallel		
	32769 - 65535	Angle +		
38	0 - 65535	Framing blade 3 (bottom): position Out → in	Fade	0
39				
40	0 - 32766	Framing blade 3 (bottom): angle Angle –	Fade	32768
41	32767 - 32768	Parallel		
	32769 - 65535	Angle +		
42	0 - 65535	Framing blade 4: (left-hand) position Out → in	Fade	0
43				
44	0 - 32766	Framing blade 4: (left-hand) angle Angle –	Fade	32768
45	32767 - 32768	Parallel		
	32769 - 65535	Angle +		

Table 3: MAC Ultra Performance Extended Mode DMX Protocol

Channel	DMX Value	Function	Fade type	Default value
46	0 - 32766	Framing module angle Angle – Parallel	Fade	32768
47	32767 - 32768 32769 - 65535			
Movement				
48	0 - 65535	Pan (16-bit) Left → right	Fade	32768
49				
50	0 - 65535	Tilt (16-bit) Forward → backward	Fade	32768
51				
Control / Settings				
52		Fixture control/settings <i>(hold for number of seconds indicated to activate)</i>	Snap	0
	0 - 9	Exit calibration adjustment and return to normal control – 5 sec.		
	10 - 14	Reset entire fixture – 5 sec.		
	15	No function		
	16	Reset color – 5 sec.		
	17	Reset beam only – 5 sec.		
	18	Reset pan and tilt only – 5 sec.		
	19 - 22	No function		
	23	Linear dimming curve – 1 sec. (menu override, setting unaffected by power off/on)		
	24	Square law dimming curve – 1 sec. (menu override, default setting, setting unaffected by power off/on)		
	25	Inverse square law dimming curve – 1 sec. (menu override, setting unaffected by power off/on)		
	26	S-curve dimming curve – 1 sec. (menu override, setting unaffected by power off/on)		
	27	Standard pan and tilt speed – 1 sec. (default setting)		
	28	Fast pan and tilt – 1 sec. (menu override - setting returns to <i>Standard pan and tilt speed</i> after power on/off)		
	29	Smooth pan and tilt – 1 sec. (menu override - setting returns to <i>Standard pan and tilt speed</i> after power on/off)		
	30	Effect shortcuts on (default setting)		
	31	Effect shortcuts off		
	32	Disable focus tracking – 1 sec.		
	33	Focus tracking = Near distance – 1 sec.		
	34	Focus tracking = Medium distance (default setting) – 1 sec.		
	35	Focus tracking = Far distance – 1 sec.		
	36	Enable video tracking		
	37	Disable video tracking (default setting)		
	38 - 51	No function		
	52	Control panel display on (default setting) – 1 sec.		
	53	Control panel display off – 1 sec.		
	54	Regulated fan speed, fixed light output intensity (default setting) – 1 sec.		
	55	Full fan speed, regulated light output intensity – 1 sec.		
56	Medium fan speed, regulated light output intensity – 1 sec.			
57	Low fan speed, regulated light output intensity – 1 sec.			
58	Ultra-low fan speed, regulated light output intensity – 1 sec.			
59 - 60	No function			
61	Hibernation mode on – 1 sec.			
62	Hibernation mode off – 1 sec.			
63	Followspot mode on – 5 sec.			
64	Followspot mode off (default setting) – 5 sec.			
65	Pan and tilt limits on – 1 sec.			
66	Pan and tilt limits off (default setting) – 1 sec.			
67	Pan limit low – 1 sec.			
68	Pan limit high – 1 sec.			
69	Tilt limit low – 1 sec.			
70	Tilt limit high – 1 sec.			
71	Reset pan and tilt limits – 1 sec.			

Table 3: MAC Ultra Performance Extended Mode DMX Protocol

Channel	DMX Value	Function	Fade type	Default value
52 contd.	72	Tungsten emulation on – 1 sec.	Snap	0
	73	Tungsten emulation off (default setting) – 1 sec.		
	74	Scene capture record – 5 sec.		
	75	Scene capture playback on – 5 sec.		
	76	Scene capture playback off (default setting) – 5 sec.		
	77 - 78	<i>No function</i>		
	79	Gobo CT correction on (default setting) – 1 sec.		
	80	Gobo CT correction off – 1 sec.		
	81 - 86	<i>No function</i>		
	87	Keylight calibration disabled – 1 sec.		
	88	Keylight calibration manual – 1 sec.		
	89	Keylight calibration automatic (default setting) – 1 sec.		
	90 - 99	<i>No function</i>		
	100	Enable calibration adjustment – 5 sec.		
	101	Store pan and tilt calibration – 5 sec.		
	102	Store dimmer calibration – 5 sec.		
	103	Store Cyan calibration – 5 sec.		
	104	Store Magenta calibration – 5 sec.		
	105	Store Yellow calibration – 5 sec.		
	106	Store CTC calibration – 5 sec.		
	107	Store all CMYC calibration – 5 sec.		
	108	Store rotating gobo wheel 1 calibration – 5 sec.		
	109	Store rotating gobo wheel 2 calibration – 5 sec.		
	110	Store animation wheel calibration – 5 sec.		
	111	Store framing system calibration – 5 sec.		
	112	Store iris calibration – 5 sec.		
	113	Store focus calibration – 5 sec.		
	114	Store zoom calibration – 5 sec.		
	115	Store color wheel calibration – 5 sec.		
	116 - 193	<i>No function</i>		
	194	Start CTO keylight calibration – 5 sec.		
	195	Start spectral enhancement keylight calibration – 5 sec.		
	196	Store CTO keylight enhancement keylight calibration – 5 sec.		
197	Store spectral enhancement keylight calibration – 5 sec.			
198	Store all calibration settings (except keylight settings) – 5 sec.			
199	Return all calibration settings (except keylight settings) to factory defaults – 5 sec.			
200 - 255	<i>No function</i>			
P3 Mix				
53	0 - 26	P3 Mix <i>DMX Mode</i> Intensity and colors fully controlled by DMX, P3 pixel data ignored	Snap	0
	27 - 228	<i>Mixed Mode</i> Cross-fade from DMX control of intensity and colors to P3 control of intensity and colors: <ul style="list-style-type: none"> At 27, intensity and colors are still fully controlled by DMX. Between 27 and 228, you mix/crossfade from DMX to P3 control. At 228, the Intensity of each of the 10 x Animation segments is controlled by 10 x separate P3 pixels and color is controlled by P3 Pixel 1 (the black pixel on the P3 map). 		
	229 - 255	<i>Video Mode</i> Intensity of 10 x Animation segments controlled by P3, color controlled by DMX (DMX channels 'color' the P3 pixel data)		
Pre-programmed FX				
54	0	FX1 selection (see FX table on page 40) No effect	Snap	0
	1 - 254	Effect selection (adjust speed and direction on channel 45)		
	255	Enable PWM frequency adjustment (adjust frequency on channel 45)		
55	0 - 126	FX1 speed and direction Effect reversed fast → slow	Fade	128
	127 - 129	Effect stops		
	130 - 255	Effect forward slow → fast		

Table 3: MAC Ultra Performance Extended Mode DMX Protocol

Channel	DMX Value	Function	Fade type	Default value
56	0	FX2 selection (see FX table on page 40) No effect	Snap	0
	1 - 159	Effect selection (adjust speed and direction on channel 47)		
	160	Enable FX1 y-axis control on channel 47		
	161 - 194	<i>No function (these FX are available for FX1 only)</i>		
	195 - 254	Effect selection (adjust speed and direction on channel 47)		
57	255	Enable PWM frequency adjustment (adjust frequency on channel 47)	Fade	128
	0 - 126	FX2 speed and direction Effect reversed fast → slow		
	127 - 129	Effect stops		
58	130 - 255	Effect forward slow → fast	Snap	36
	0	FX synchronization No sync		
	1	Offset shift 10°		
	2	Offset shift 20°		
	3	Offset shift 30°		
	4	Offset shift 40°		
	5	Offset shift 50°		
	6	Offset shift 60°		
	7	Offset shift 70°		
	8	Offset shift 80°		
	9	Offset shift 90°		
	10	Offset shift 100°		
	11	Offset shift 110°		
	12	Offset shift 120°		
	13	Offset shift 130°		
	14	Offset shift 140°		
	15	Offset shift 150°		
	16	Offset shift 160°		
	17	Offset shift 170°		
	18	Offset shift 180°		
	19	Offset shift 190°		
	20	Offset shift 200°		
	21	Offset shift 210°		
	22	Offset shift 220°		
	23	Offset shift 230°		
	24	Offset shift 240°		
	25	Offset shift 250°		
	26	Offset shift 260°		
	27	Offset shift 270°		
	28	Offset shift 280°		
29	Offset shift 290°			
30	Offset shift 300°			
31	Offset shift 310°			
32	Offset shift 320°			
33	Offset shift 330°			
34	Offset shift 340°			
35	Offset shift 350°			
36	Synchronized: all fixtures start FX cycles at same time			
37 - 100	<i>No function</i>			
101 - 120	Random start (Channel 45 controls overall speed)			
121 - 140	Random duration			
141 - 255	<i>No function</i>			

Table 3: MAC Ultra Performance Extended Mode DMX Protocol

FX: pre-programmed effects

FX are implemented in the MAC Ultra Performance firmware version 1.5.0. You can quickly check which firmware version a fixture is running using INFORMATION → FW VERSION in the fixture's control menus. For information on updating firmware, see the MAC Ultra Performance Safety and Installation Manual supplied with the fixture and available for download from www.martin.com.

The table on the following pages lists the pre-programmed dynamic FX (effect macros) available in the MAC Ultra Performance. To control the FX you can:

- Select an effect, or two effects that can run simultaneously, on DMX channels 44 and 46 by sending the values listed in the table.
- Adjust effect speed on channels 45 and 47.
- Adjust synchronization of effects across different fixtures on channel 48.

Effects types

Intensity FX (1-15)

These effects modulate the intensity of the output while keeping the color(s) set on the CMY and color wheel channels and any other effects applied.

Animation effects (32-46)

The MAC Ultra Performance's Animation effects modulate the ten individual segments of the fixture's LED engine individually, leading to unique animated effects.

Color FX (64-91)

These effects override the color(s) set on the CMY and color wheel channels.

Beam shaping FX (96-110)

These effects use the fixture's iris, zoom and prism to dynamically change the shape of the beam.

Gobo FX (128-143)

These effects apply dynamic movement to gobos. Certain effects add zoom to the movement.

Gobo 1 FX are applied to the gobo that is currently selected on gobo wheel 1 and Gobo 2 FX are applied to the gobo that is currently selected on gobo wheel 2.

Framing FX (160-194)

These effects use the fixture's framing system to give static and dynamic beam shapes.

FX 160, FX2 y-axis selection, is available on the FX2 Selection channel 46 only. Selecting FX 160 on channel 46 changes the function of channel 47. If you select FX 160 on channel 46, channel 47 now lets you adjust the y-axis of any FX from 161 - 194 that you select on the FX1 Selection channel 44.

FX 161 - 194 are available on the FX1 Selection channel 44 only.

Pan and tilt FX (224-235)

These effects use pan and tilt to move the beam following pre-programmed shapes.

PWM Tune (255)

Sending DMX value 255 on one of the FX selection channels 44 or 46 lets you adjust the LED PWM frequency. See "LED PWM frequency control" on page 11 for details.

Effects types

Available in MAC Ultra Performance firmware version 1.5.0.

DMX value	Effect
0	No FX
Intensity FX	
1	Strobe Pulse Width (when Strobe is activated on Channel 1)
2	Wave (sine wave)
3	Step (50/50 on/off)
4	Pulse
5	Blackout Strobe
6	2x Strobe
7	3x Strobe
8	4x Strobe
9	Up, Down, Flash
10	Up, Flash, Down, Flash
11	Random Levels
12	Electric Arc
13	Atomic Lighting
14	Thunderstorm
15	Welding
16 - 31	No function
Animation FX	
32	Stop Motion
33	Movie Flicker
34	Random Dimmers
35	Shakey Dimmers
36	Negative Pulse
37	Positive Pulse
38	Radar Wave
39	Radar Step
40	Radar Pulse
41	Odd/Even Wave
42	Odd/Even Step
43	Odd/Even Pulse
44	5-Step Wave
45	5-Step Step
46	5-Step Pulse
47 - 63	<i>No function</i>
Color FX	
64	Rainbow Wave
65	Rainbow Step
66	Rainbow Pulse
67	RGB Wave
68	RGB Step
69	RGB Pulse
70	CMY Wave
71	CMY Step
72	CMY Pulse
73	Mix to White Wave
74	Mix to White Step

Table 4: FX in the MAC Ultra Performance

75	Mix to White Pulse
76	Random Mix Wave
77	Random Mix Step
78	Random Mix Pulse
79	Random Subtle Wave
80	Red White Blue Fade
81	Red White Blue Snaps
82	Full Bumps
83	All Bumps
84	Split Bumps
85	Random Split Bumps
86	Color Shaker
87	Fire
88	Water
89	Ice
90	Hot and Cold
91	Warm and Fuzzy
92 - 95	<i>No function</i>
Beam Shaping FX	
96	Iris Wave (sine wave)
97	Iris Step (50/50 on/off)
98	Iris Pulse
99	Zoom Wave (sine wave, keeps current speed mode)
100	Zoom Step (50/50 on/off, keeps current speed mode)
101	Zoom Pulse (keeps current speed mode)
102	Random Size Wave
103	Random Size Step
104	Random Size Pulse
105	Prism Quarter Tick Tock
106	Prism Half Tick Tock
107	Prism Full Tick Tock
108	Beam Splash
109	Beam Splash Invert
110	Pin to Flood (keeps current speed mode)
111 - 127	<i>No function</i>
Gobo and Animation FX	
128	Gobo 1 Tick Tick Tick
129	Gobo 1 Quarter Tick Tock
130	Gobo 1 Half Tick Tock
131	Gobo 1 Full Tick Tock
132	Gobo 1 Fade Spin Zoom
133	Gobo 1 Twist
134	Gobo 1 Expand Twist
135	Gobo 1 Collapse Twist
136	Gobo 2 Tick Tick Tick
137	Gobo 2 Quarter Tick Tock
138	Gobo 2 Half Tick Tock
139	Gobo 2 Full Tick Tock
140	Gobo 2 Fade Spin Zoom
141	Gobo 2 Twist
142	Gobo 2 Expand Twist
143	Gobo 2 Collapse Twist
144 - 159	<i>No function</i>

Table 4: FX in the MAC Ultra Performance

Framing FX	
160	When selected on channel 46, FX160 enables y-axis selection on channel 47 for FX 167-194 if one of these is selected on channel 44.
161	Vertical Bar Slim
162	Vertical Bar Medium
163	Vertical Bar Large
164	Horizontal Bar Slim
165	Horizontal Bar Medium
166	Horizontal Bar Large
167	Small Square
168	Medium Square
169	Large Square
170	Small Horizontal Rectangle
171	Medium Horizontal Rectangle
172	Large Horizontal Rectangle
173	Small Vertical Rectangle
174	Medium Vertical Rectangle
175	Large Vertical Rectangle
176	Small Parallelogram Left
177	Medium Parallelogram Left
178	Small Parallelogram Right
179	Medium Parallelogram Right
180	Vertical Bar Slim to Horizontal Bar Slim
181	Vertical Bar Medium to Horizontal Bar Medium
182	Vertical Bar Large to Horizontal Bar Large
183	Vertical Bar Slim to Medium Square
184	Vertical Bar Medium to Medium Square
185	Horizontal Bar Slim to Medium Square
186	Horizontal Bar Medium to Medium Square
187	Medium Square to Medium Horizontal Rectangle
188	Medium Square to Medium Vertical Rectangle
189	Medium Square to Large Horizontal Rectangle
190	Medium Square to Large Vertical Rectangle
191	Small Square to Small Parallelogram Left
192	Medium Square to Medium Parallelogram Left
193	Small Square to Small Parallelogram Right
194	Medium Square to Medium Parallelogram Right
195 - 223	<i>No function</i>

Table 4: FX in the MAC Ultra Performance

Pan/Tilt FX	
224	Pan and Tilt Circle Small
225	Pan and Tilt Circle Medium
226	Pan and Tilt Circle Large
227	Pan and Tilt Figure 8 Small
228	Pan and Tilt Figure 8 Medium
229	Pan and Tilt Figure 8 Large
230	Pan and Tilt Diagonal Line Small
231	Pan and Tilt Diagonal Line Medium
232	Pan and Tilt Diagonal Line Large
233	Pan and Tilt Square Small
234	Pan and Tilt Square Medium
235	Pan and Tilt Square Large
236 - 254	<i>No function</i>
Full fixture	
255	PWM Tune

Table 4: FX in the MAC Ultra Performance

Control panel menus

MAC Ultra Performance firmware version 1.5.0.

Menu level 1	Menu level 2	Menu level 3	Menu level 4	Notes (Default settings in bold print)	
DMX SETUP	DMX ADDRESS	1 – XXX		DMX address (default address = 1). The DMX address range is limited so that the fixture will always have enough DMX channels within the 512 available.	
	CONTROL MODE	BASIC		Basic DMX control mode	
		EXTENDED		Extended DMX control mode	
	DMX UNIVERSE	1 - 64000		Set DMX universe	
ETHERNET SETUP	IP ADDRESS	XXX.XXX.XXX.XXX		Display fixture's static IP address	
		PART 1 MSB		Set far left block (most significant byte) of IP address	
		PART 2		Set middle left block of IP address	
		PART 3		Set middle right block of IP address	
		PART 4 LSB		Set far right block (most significant byte) of IP address	
	SUBNET MASK	XXX.XXX.XXX.XXX		Display fixture's subnet mask	
		EDIT SUBNET MASK	XXX.XXX.XXX.XXX	Display fixture's subnet mask	
			XXX.XXX.XXX.XXX	Set subnet mask with 1 bit increments from the left	
	MAC ADDRESS	XX:XX:XX:XX:XX:XX		Display fixture's MAC address	
RESET IP SETUP	RESET	ARE YOU SURE? YES/NO	Reset static IP address and subnet mask to default values		
FIXTURE ID	0 – 9999			User-settable 4-digit fixture ID number (default = 0)	
PERSONALITY	PAN/TILT	PAN INVERT	ON/OFF	Inverse DMX pan control: right → left	
		TILT INVERT	ON/OFF	Inverse DMX tilt control: down → up	
		FOLLOWSPOT MODE	ON/OFF	Enable followspot mode: pan/tilt motors disabled, head can be moved manually	
		LIMIT PAN/TILT	LIMIT ENABLE	ON/OFF	Enable limits for pan and tilt
			PAN MIN →	-32767	Set minimum pan angle limit
			PAN MAX →	32768	Set maximum pan angle limit
			TILT MIN →	-32767	Set minimum tilt angle limit
			TILT MAX →	32768	Set maximum tilt angle limit
RESET PAN/TILT LIMITS		Confirm with: ARE YOU SURE? YES/NO	Returns fixture to default pan/tilt limits. The default limits match GT Truss with half-coupler rigging clamps.		

Table 5: Control menus

Menu level 1	Menu level 2	Menu level 3	Menu level 4	Notes (Default settings in bold print)
PERSONALITY (continued)	SPEED	PAN/TILT	FAST	Optimize pan/tilt movement for speed
			SMOOTH	Optimize pan/tilt movement for smoothness
			STANDARD	Standard pan/tilt movement, balances speed and smoothness
		EFFECT	FAST	Optimize effects movement for speed
			SMOOTH	Optimize effects movement for smoothness
			STANDARD	Standard effects movement, balances speed and smoothness
			FOLLOW P/T	Effects speed follows the speed setting applied to pan and tilt via DMX or in control menu
		DIMMER CURVE	LINEAR	
	SQUARE LAW			Square law dimming curve
	INV SQ LAW			Inverse square law dimming curve
	S-CURVE			S-curve (fixture emulates incandescent lamp voltage linear RMS dimming curve)
	TUNGSTEN EMULATOR	ON		Color temperature and dimming characteristics emulate tungsten lamp behavior
		OFF		
	FOCUS TRACKING	FAR		Focus adjusts to match zoom: optimized for long range projection
		MEDIUM		Focus adjusts to match zoom: optimized for mid-range projection
		NEAR		Focus adjusts to match zoom: optimized for close range projection
		DISABLED		Focus tracking function disabled
	VIDEO TRACKING	ENABLED		Color fading optimized for speed of color changes
		DISABLED		Color fading optimized for smoothness
	DMX RESET	ON		Fixture can be reset via DMX
		OFF		Fixture cannot be reset via DMX (note that this menu item can be overridden: see DMX protocol)
	EFFECT SHORTCUT	ON		Effects take shortest route during changes, crossing open positions if necessary
		OFF		Effects avoid open positions during effects changes
	COOLING MODE	CONSTANT FAN FULL		Fans optimized for maximum light intensity, fans run at full speed, light intensity reduced if necessary to keep fixture within temperature limits
		CONSTANT FAN MEDIUM		Fans run at medium speed, light intensity reduced if necessary to keep fixture within temperature limits
		CONSTANT FAN LOW		Fans run at low speed, light intensity reduced if necessary to keep fixture within temperature limits
		CONSTANT FAN ULOW		Fans optimized for lowest noise, fans run at ultra-low speed, light intensity reduced if necessary to keep fixture within temperature limits
		REGULATE FANS		Compromise between light intensity and quietness, fan speed temperature-regulated, light intensity only reduced if fans reach full speed and further action necessary to keep fixture within temperature limits

Table 5: Control menus

Menu level 1	Menu level 2	Menu level 3	Menu level 4	Notes (Default settings in bold print)
PERSONALITY (continued)	GOBO CT CORRECTION	ENABLED		Automatic color temperature correction when gobo is inserted into beam
		DISABLED		No automatic color temperature correction
	DISPLAY	DISPLAY SLEEP	10 MINUTES	Display goes into sleep mode 10 minutes after last key press
			5 MINUTES	Display goes into sleep mode five minutes after last key press
			2 MINUTES	Display goes into sleep mode two minutes after last key press
			ON	Display permanently on
		DISPLAY INTENSITY	10 ... 100 %	Set display intensity in % (default = 100)
		DISPLAY ROTATION	NORMAL	Display orientation normal
			ROTATE 180	Display orientation rotated 180°
	DISPLAY CONTRAST	3 ... 41 ... 100	Adjust contrast of display (default = 41)	
	ERROR MODE	NORMAL		Enable error messages and warnings in display
		SILENT		Disable error messages and warnings in display (the status LED will still light to indicate fixture status if an error has been detected or the fixture has a warning)
	HIBERNATION MODE	ON		Enable Hibernation Mode (light output set to zero, all effect movement disabled)
		OFF		Disable Hibernation Mode
	SCENE CAPTURE	RECORD	SAVE	Saves all current DMX values as playback scene
PLAYBACK		ENABLE	Sets fixture to run currently saved playback scene after power cycle / reset. Any new DMX input disables scene playback until next power cycle.	
		DISABLE	Disable scene playback functionality	
DEFAULT SETTINGS	FACTORY DEFAULT	LOAD	ARE YOU SURE? YES/NO	Return all settings (except calibrations) to factory defaults
	CUSTOM 1	LOAD	ARE YOU SURE? YES/NO	Load Custom Settings 1
		SAVE	ARE YOU SURE? YES/NO	Save fixture's current settings as Custom Settings 1
	CUSTOM 2	LOAD	ARE YOU SURE? YES/NO	Load Custom Settings 2
		SAVE	ARE YOU SURE? YES/NO	Save fixture's current settings as Custom Settings 2
	CUSTOM 3	LOAD	ARE YOU SURE? YES/NO	Load Custom Settings 3
		SAVE	ARE YOU SURE? YES/NO	Save fixture's current settings as Custom Settings 3

Table 5: Control menus

Menu level 1	Menu level 2	Menu level 3	Menu level 4	Notes (Default settings in bold print)
INFORMATION	POWER ON TIME	TOTAL	0 ... XXX HR	Display hours fixture has been powered on since manufacture (not user-resettable)
		RESETTABLE	CLEAR COUNTER? YES/NO	Display hours fixture has been powered on since last counter reset (user-resettable)
	POWER ON CYCLES	TOTAL	0 ... XXX HR	Display number of times fixture has been powered on since manufacture (not user-resettable)
		RESETTABLE	CLEAR COUNTER? YES/NO	Display number of times fixture has been powered on since last counter reset (user-resettable)
	FW VERSION*	XX.XX.XX		Displays currently active firmware version
	RDM UID*	4D50.XXXXXXXX		Displays fixture's unique RDM ID
	FAN SPEEDS*	HEAD FAN 1 -12 BASE FAN 1 - 4	0 - XXX RPM	Scroll to display current speed of each cooling fan (head and base)
	TEMPERATURES*	UI ... CURRENT DRIVER	CURRENT / MIN / MAX X C	Scroll through PCB temperature sensors, then display current, minimum* and maximum* temperature in °C of all PCBs *Since fixture was last reset / powered on
DMX LIVE*	RATE	0 - 44 HZ		DMX transmission speed in packets per second
	QUALITY	0 - 100%		Percent of packets received
	START CODE	0 - 255		Value of the DMX start code
	STROBE ... FX SYNC	XXX		Scroll to see values received on each DMX channel
TEST*	TEST ALL	DIMMER ... TILT		Run test sequence of all functions To test a specific function, use Up/Down buttons to scroll through functions. Press Enter to pause and press again to restart test sequence. Press Menu button to exit test
	TEST LEDS	DIMMER		Run test sequence of LEDs only. Press Menu button to exit test
	TEST EFFECTS	CMY ... FOCUS		Run test sequence of effects. To test a specific effect, use Up/Down buttons to scroll through groups. Press Enter to pause and press again to restart test sequence. Press Menu button to exit test
	TEST PAN/TILT	PAN		Run test sequence of pan functions. Press Menu button to exit test
		TILT		Run test sequence of tilt functions. Press Menu button to exit test
MANUAL CONTROL*	RESET	ALL		Reset fixture
	STROBE / SHUTTER ... P3 MIX MODE			Scroll through effects, then manually control an effect

Table 5: Control menus

Menu level 1	Menu level 2	Menu level 3	Menu level 4	Notes (Default settings in bold print)	
SERVICE* (see "Activating service mode" on page 14)	ERROR LIST	Empty or up to 20 errors		Show all error and warning messages stored in memory.	
	FAN CLEAN	ON/OFF		Run cooling fans at high speed to dislodge dust and debris.	
	PAN/TILT FEEDBACK	ON		Enable pan/tilt position feedback system	
		OFF		Disable pan/tilt position feedback system	
	ADJUST (for use by or with guidance from Martin Service only)	PAN/TILT AT END STOP	STEP 1	To adjust, move head to end position and press ENTER	
			STEP 2	To adjust, move head to end position again and press ENTER	
		FROST	NOT ADJUSTED 0 - 255	Adjust full frost position	
	CALIBRATION	GOBO W1 SEL ... TILT	<i>Calibration range varies depending on effect</i>		Scroll through effects, press Enter to select. Adjust position and press Enter to confirm.
		LOAD DEFAULTS	LOAD		Load factory default calibration settings
		SAVE DEFAULTS	SAVE		Replace factory default calibration settings with current calibration settings
	EXPECTED MODULES	MODULE STATUS	PAN ... PIXEL BEAM 1 FOUND / MISSING		Lists internal effect modules that the fixture expects to detect and reports them as either FOUND or MISSING
		UNKNOWN MODULE	NONE AVAILABLE		Every module has been detected as UNKNOWN
			XXXX (PAN ... PIXEL BEAM 1)		One module is displayed with a red flashing LED – identify which module is has the flashing LED and choose the module from the UNKNOWN module list to make it KNOWN
DELETE MODULE		PAN ... PIXEL BEAM 1		CAUTION! Deletes module type ID. Module will now be detected as UNKNOWN	
SERVICE (continued)	USB	NO DEVICE		No USB memory device detected at USB port or no firmware detected on USB memory device	
		UPDATING FILES		Fixture updating internal memory from USB memory device	
		AVAILABLE FIRMWARE	XX.XX.XX ... XX.XX.XX	Select firmware from versions stored in internal memory. Scroll to select version, then press Enter and confirm your choice to update.	

Table 5: Control menus

*The TEMPERATURES, DMX LIVE, MANUAL CONTROL and SERVICE menus are not available when the fixture is operating on battery power.

Service and display messages

The MAC Ultra Performance gives service and maintenance information by displaying a large 3- or 4-character short code and a smaller full-text message in the fixture's display. The short code is visible at a distance, allowing easier reading with the fixture still in the rig, for example, while the full-text message gives more detailed information.

Excessively high temperatures

If any of the temperature sensors reports that the fixture has exceeded its recommended temperature range, the fixture reports a temperature warning and reduces light output to reduce its temperature. If the temperature reaches a dangerous level, light output is shut down completely.

Temperature warnings are canceled and full light output becomes available again as soon as the temperature returns to normal.

Warning messages

Warning messages indicate that either:

- problems might appear in the future if no action is taken, or
- the user needs to pay special attention to a function or procedure when working with the fixture.

The MAC Ultra Performance communicates warnings as follows:

- Warning codes are shown continuously in the display and disappear when the user reacts to the warning.
- If more than one warning is detected, all warnings are displayed in sequence.
- If the display is inactive, the fixture's status LED (see Figure 5 on page 12) flashes orange to indicate that there is a warning. Activating the display will show the warning.

The possible warning messages are listed in Table 6 below:

Short code	Long message and explanation
BANK	BANK NO ACCESS Error unpacking firmware bank during/after software upload. Fixture will continue to operate on existing firmware. Warning message is cleared by a successful software upload or at the next power off/on cycle.
BATM	BATTERY MODE Fixture in battery mode. Certain control menu items are not available.
BETW	BEAM TMP HIGH LED beam pixels sensor detects abnormally high operating temperature.*
CMTW	CMY TEMP HIGH CMY module sensor detects abnormally high operating temperature.*
EFTW	EFF TEMP HIGH Effects module sensor detects abnormally high operating temperature.*
F2TW	FRAMING2 TMP HIGH Framing module sensor 2 detects abnormally high operating temperature.*
FRTW	FRAMING TMP HIGH Framing module sensor 1 detects abnormally high operating temperature.*
FTNA	FROST ADJUST Frost effect out of adjustment range.
G11M	GOBO 1-1 MISSING Gobo Wheel 1: Gobo 1 not detected.
G21M	GOBO 2-1 MISSING Gobo Wheel 2: Gobo 1 not detected.

Table 6: Warning messages

Short code	Long message and explanation
LDTW	LED DRV TMP HIGH LED Driver PCB sensor detects abnormally high operating temperature.*
LETW	LED BOARD TEMP HIGH LED PCB sensor detects abnormally high operating temperature.*
PNTW	PAN TEMP HIGH Pan motor sensor detects abnormally high operating temperature.*
PUTW	PSU TEMP HIGH PSU sensor detects abnormally high operating temperature.*
SERV	SERVICE MODE Fixture in service mode.
TLTW	TILT TEMP HIGH Tilt motor sensor detects abnormally high operating temperature.*
UITW	UI TEMP HIGH User interface (LCD display and control panel) PCB sensor detects abnormally high operating temperature.*
ZFTW	ZF TEMP HIGH Zoom/focus PCB sensor detects abnormally high operating temperature.*

Table 6: Warning messages

**High temperature warnings are canceled as soon as temperature returns to normal. If temperature reaches cutoff level, the warning is replaced by a cutoff error message.*

Error messages

Error messages indicate that a problem is present. The MAC Ultra Performance communicates errors as follows:

- Error messages flash in the display.
- If more than one error is detected, the fixture flashes all errors three times each.
- Errors are shown in the display regardless of display status: they override an inactive display and any other information that the display might be showing.
- If an error is present, the status LED flashes red.

The possible error messages are listed in Table 7 below:

Short code	Long message and explanation
APER	AW POS ERROR Animation Wheel position error.
ARER	AW ROT ERROR Animation Wheel rotation error.
BETC	BM TMP CUT OFF LED beam pixels temperature cutoff activated.
BETE	BM TMP SEN ERR LED beam pixels temperature sensor error.
C1ER	COLORWHEEL 1 ERR Color Wheel error.
CECM	COM ERR CMY CMY module communication error.
CEEF	COM ERR EFFECT Effects module communication error.
CELD	COM ERR LED DRV LED driver communication error.
CEPN	COM ERR PAN Pan system communication error.

Table 7: Error messages

Short code	Long message and explanation
CETL	COM ERR TILT Tilt system communication error.
CEZF	COM ERR Z/F Zoom/focus effect communication error.
CMTC	CMY TEMP CUTOFF CMY module temperature cutoff activated.
CMTE	CMY TEMP SEN ERR CMY module temperature sensor error.
COLD	FIXTURE COLD Fixture too cold. Physical movement of effects is disabled until fixture has warmed up.
CTER	CTC ERROR CTC flag position error.
CYER	CYAN ERROR Cyan flag position error.
EFTC	EFF TEMP CUTOFF Effects module temperature cutoff activated.
EFTE	EFF TEMP SEN ERR Effects module temperature sensor error.
F2TC	FROST TEMP CUTOFF Frost effect temperature cutoff activated.
F2TE	FROST TEMP SEN ERR Frost effect temperature sensor error.
FAN	BASE FAN 1 ERR
FAN	BASE FAN 2 ERR
FAN	BASE FAN 3 ERR
FAN	BASE FAN 4 ERR
FAN	HEAD FAN 1 ERR
FAN	HEAD FAN 2 ERR
FAN	HEAD FAN 3 ERR
FAN	HEAD FAN 4 ERR
FAN	HEAD FAN 5 ERR
FAN	HEAD FAN 6 ERR
FAN	HEAD FAN 7 ERR
FAN	HEAD FAN 8 ERR
FAN	HEAD FAN 9 ERR
FAN	HEAD FAN 10 ERR
FAN	HEAD FAN 11 ERR
FAN	HEAD FAN 12 ERR
FBEP	PAN FBACK ERR Pan position magnetic indexing system timeout. Fixture is unable to correct pan position (but pan movement will often still be possible).
FBET	TILT FBACK ERR Tilt position magnetic indexing system timeout. Fixture is unable to correct tilt position (but tilt movement will often still be possible).
FOER	FOCUS ERROR Focus position error.
FRCE	FRAMING COM ERROR Framing module communication error.
FRTC	FR TEMP CUTOFF Framing module temperature cutoff activated.
FSER	FRAMING1 INS ERR Framing blade 1 insertion position error.

Table 7: Error messages

Short code	Long message and explanation
FSER	FRAMING1 ANG ERR Framing blade 1 angle position error.
FSER	FRAMING2 INS ERR Framing blade 2 insertion position error.
FSER	FRAMING2 ANG ERR Framing blade 2 angle position error.
FSER	FRAMING3 INS ERR Framing blade 3 insertion position error.
FSER	FRAMING3 ANG ERR Framing blade 3 angle position error.
FSER	FRAMING4 INS ERR Framing blade 4 insertion position error.
FSER	FRAMING4 ANG ERR Framing blade 4 angle position error.
G1ER	GOBO W 1 ERR Gobo Wheel 1 position error.
G2ER	GOBO W 2 ERR Gobo Wheel 2 position error.
IRER	IRIS ERROR Iris effect position error.
LDTC	LED TEMP CUTOFF LED temperature cutoff activated.
LDTE	LED TEMP SEN ERR LED temperature sensor error.
LETC	LED BOARD TMP CUTOFF LED PCB temperature sensor cutoff activated.
LETE	LED BOARD SEN ERR LED PCB temperature sensor error.
MAER	MAGENTA ERR Magenta flag position error.
MMER	MISSING MODULE ERR Impossible to communicate with a module that should be present. Module missing or not correctly connected.
PAER	PAN ERROR Pan position electrical indexing system timeout.
PNTC	PAN TEMP CUTOFF Pan motor temperature cutoff activated.
PNTE	PAN TEMP SEN ERR Pan motor temperature sensor error.
PRIR	PRISM INS ERR Prism insertion position error.
PRRO	PRISM ROT ERR Prism rotation error.
PSER	PAN SENSOR ERROR Fixture unable to retrieve reliable data from pan position sensor.
PTCM	P/T SENSOR ADJUST Pan/tilt sensors are incorrectly adjusted.
PUTC	PSU TEMP CUTOFF PSU temperature cutoff activated.
PUTE	PSU TEMP SEN ERR PSU temperature sensor error.
R1ER	GOBO W 1 ROT ERR Gobo Wheel 1 rotation error.
R2ER	GOBO W 2 ROT ERR Gobo Wheel 2 rotation error.

Table 7: Error messages

Short code	Long message and explanation
RFER	FRAM ROT ERR Framing module rotation error.
SEER	ARTNET SOURCES EXCEED Number of Art-Net control sources exceeded.
SEER	SACN SOURCES EXCEEDED Number of sACN control sources exceeded.
SLER	SAFETY LOOP Safety loop circuit activated. A temperature circuit breaker has shut down LEDs. Circuit breaker resets automatically after temperature has returned to normal operating range.
TIER	TILT ERROR Tilt position electrical indexing circuit timeout.
TLTC	TILT TEMP CUTOFF Tilt motor temperature cutoff activated.
TLTE	TILT TEMP SEN ERR Tilt motor temperature sensor error.
TSER	TILT SENSOR ERR Fixture unable to retrieve reliable data from tilt position sensor.
UECM	UPL ERR CMY Could not upload new CMY software during a firmware upload. Error cleared when new firmware is uploaded successfully or power is cycled off and on.
UEEF	UPL ERR EFFECT Could not upload new effects software during a firmware upload. Error cleared when new firmware is uploaded successfully or power is cycled off and on.
UELD	UPL ERR LED DRV Could not upload new LED driver software during a firmware upload. Error cleared when new firmware is uploaded successfully or power is cycled off and on.
UEPN	UPL ERR PAN Could not upload new pan system software during a firmware upload. Error cleared when new firmware is uploaded successfully or power is cycled off and on.
UETL	UPL ERR TILT Could not upload new tilt system software during a firmware upload. Error cleared when new firmware is uploaded successfully or power is cycled off and on.
UEZF	UPL ERR Z/F Could not upload new zoom/focus system software during a firmware upload. Error cleared when new firmware is uploaded successfully or power is cycled off and on.
UITC	UI TEMP CUTOFF User interface (LCD display and control panel) temperature cutoff activated.
UITE	UI TEMP SEN ERR User interface (LCD display and control panel) temperature sensor error.
WEER	WASH EFFECT ERROR Wash effect position error.
YEER	YELLOW ERROR Yellow flag position error.
ZFTC	ZF TEMP CUTOFF Zoom/focus module temperature cutoff activated.
ZFTE	ZF TEMP SEN ERR Zoom/focus module temperature sensor error.
ZOER	ZOOM ERROR Zoom car position error.

Table 7: Error messages

